



Change and Innovation  
**Create New Value**

# **Current Priority Management Issues and Business Strategy**

June 2, 2017

 **SUMITOMO CHEMICAL**

**Masakazu Tokura**  
President

# Contents

Create New Value

	Performance Trends	03-06
	What Sumitomo Chemical Strives To Be	07-13
	Progress in Achieving Goals Mainly in Core Businesses	14-51
	Initiatives toward Sustained Growth	52-64
	Conclusion	65-67
	(Reference) Topics by Sector	69-92



# Performance Trends

# Performance Trends

(Billions of yen)

**Record high profits**

**Record high profits** **All-time high**

(Billions of yen)



# Change in Business Portfolio

## Composition of Record Profits (Operating Income + Equity in Earnings of Affiliates)\*

(Billions of yen)

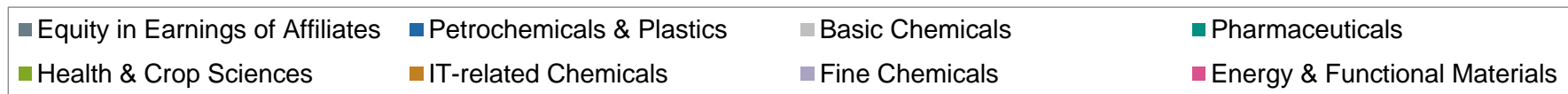
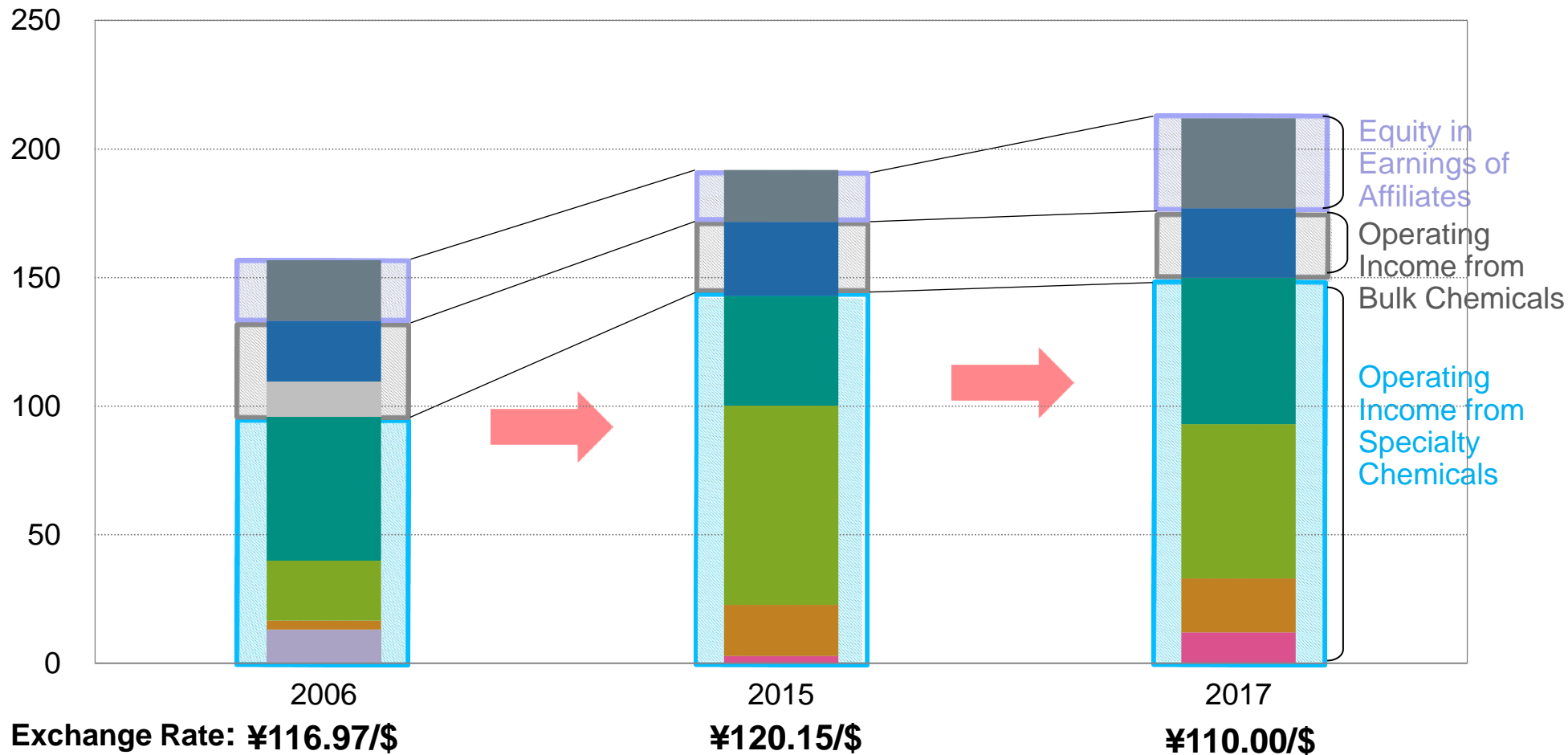

※Excluding the "Others" sector and elimination

# Dividend Policy

We consider shareholder return as one of our priority management issues and have made it a policy to maintain stable dividend payment, giving due consideration to our business performance and a dividend payout ratio for each fiscal period, the level of retained earnings necessary for future growth, and other relevant factors.

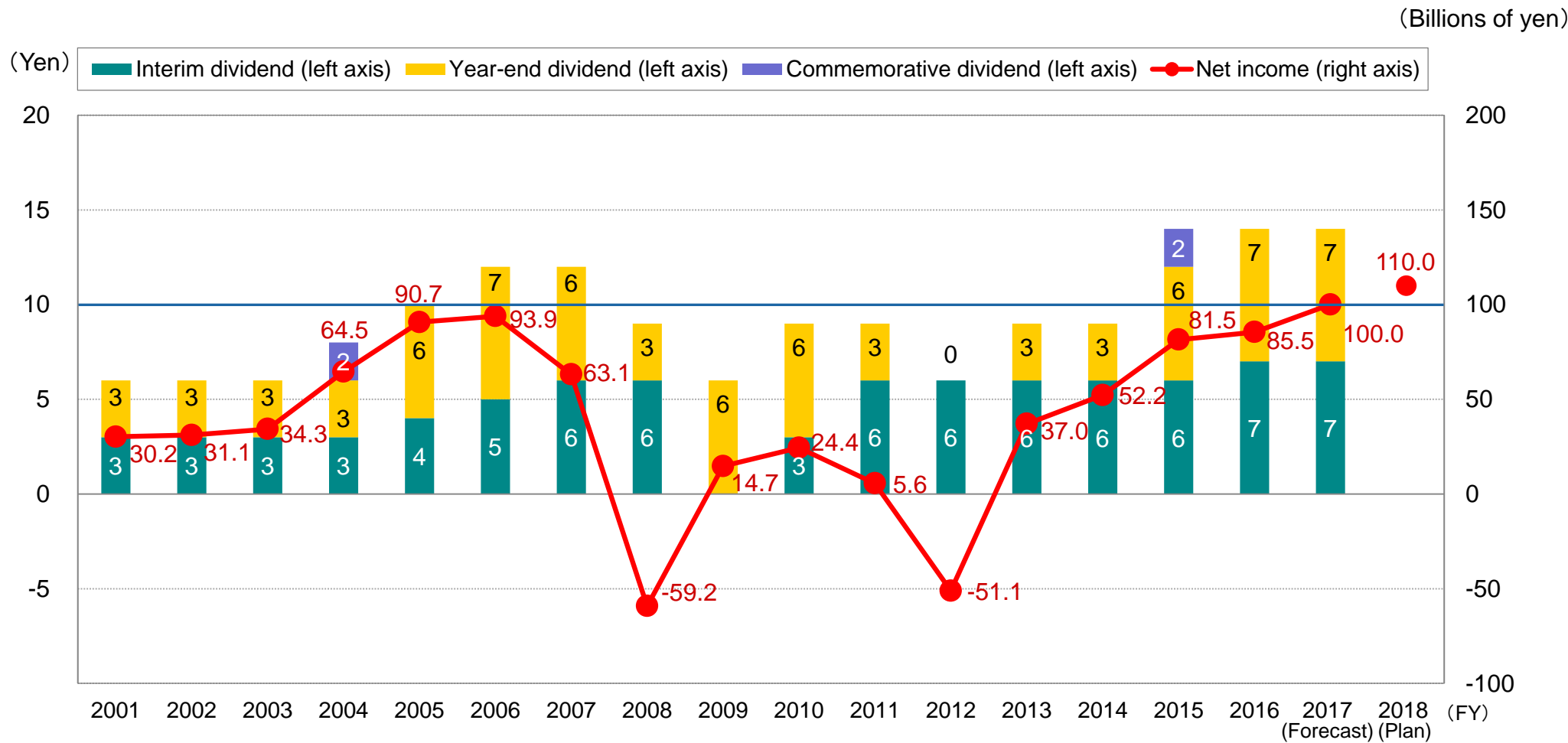

# What Sumitomo Chemical Strives To Be

# What Sumitomo Chemical Strives To Be

**Business Philosophy**

- ◆ Commit ourselves to creating new value by building on innovation
- ◆ Work to contribute to society through our business activities
- ◆ Develop a vibrant corporate culture and continue to be a company that society can trust

**Core Competence**

Capabilities to develop innovative solutions by leveraging its technological expertise in diverse areas

Capabilities to reach global markets

Loyal employees



**Challenges & Business Opportunities**

Solve issues facing society

- Environment
- Food
- Resources and energy

Improve quality of life and build an affluent and comfortable society

- Health promotion
- Comfortable life



**Achieve sustained growth by creating new value through innovative technologies**





# What Sumitomo Chemical Strives To Be: Achieve Sustained Growth

## Medium- to long-term targets

Consistently achieve  
the following targets:

**ROE**  
over 10%

**ROI**  
over 7%

**D/E ratio**  
approx.  
0.7 times

**Dividend  
payout  
ratio**  
approx. 30%

**Profit  
growth**  
over 7%  
per year

**Become a more resilient Sumitomo Chemical  
that achieves sustained growth**

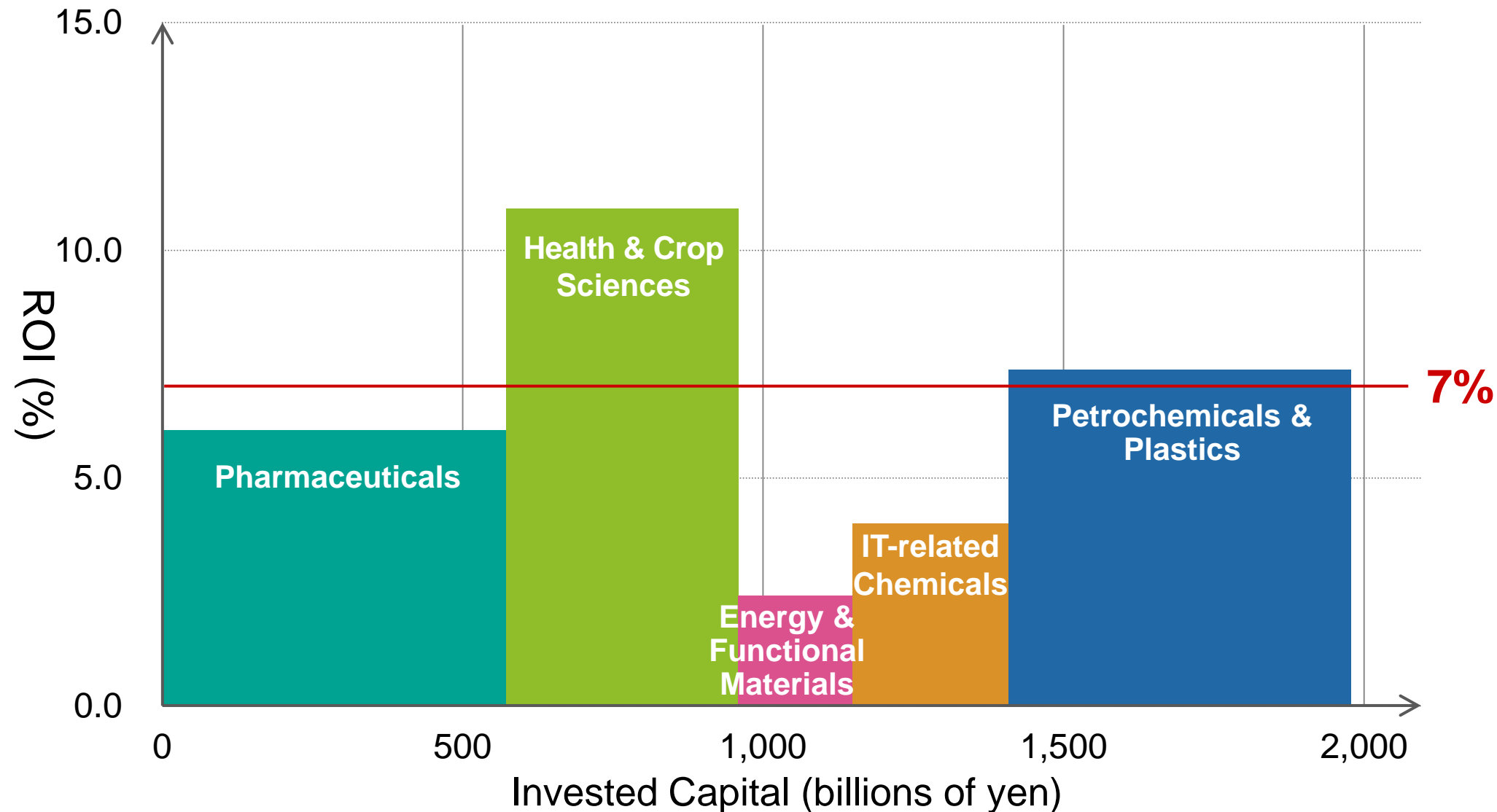
What Sumitomo Chemical Strives To Be: **Current Business Portfolio****Invested Capital and ROI by Sector (Forecast for FY2017)**

# What Sumitomo Chemical Strives To Be: Improvement of Business Portfolio

## Invested Capital and ROI by Sector

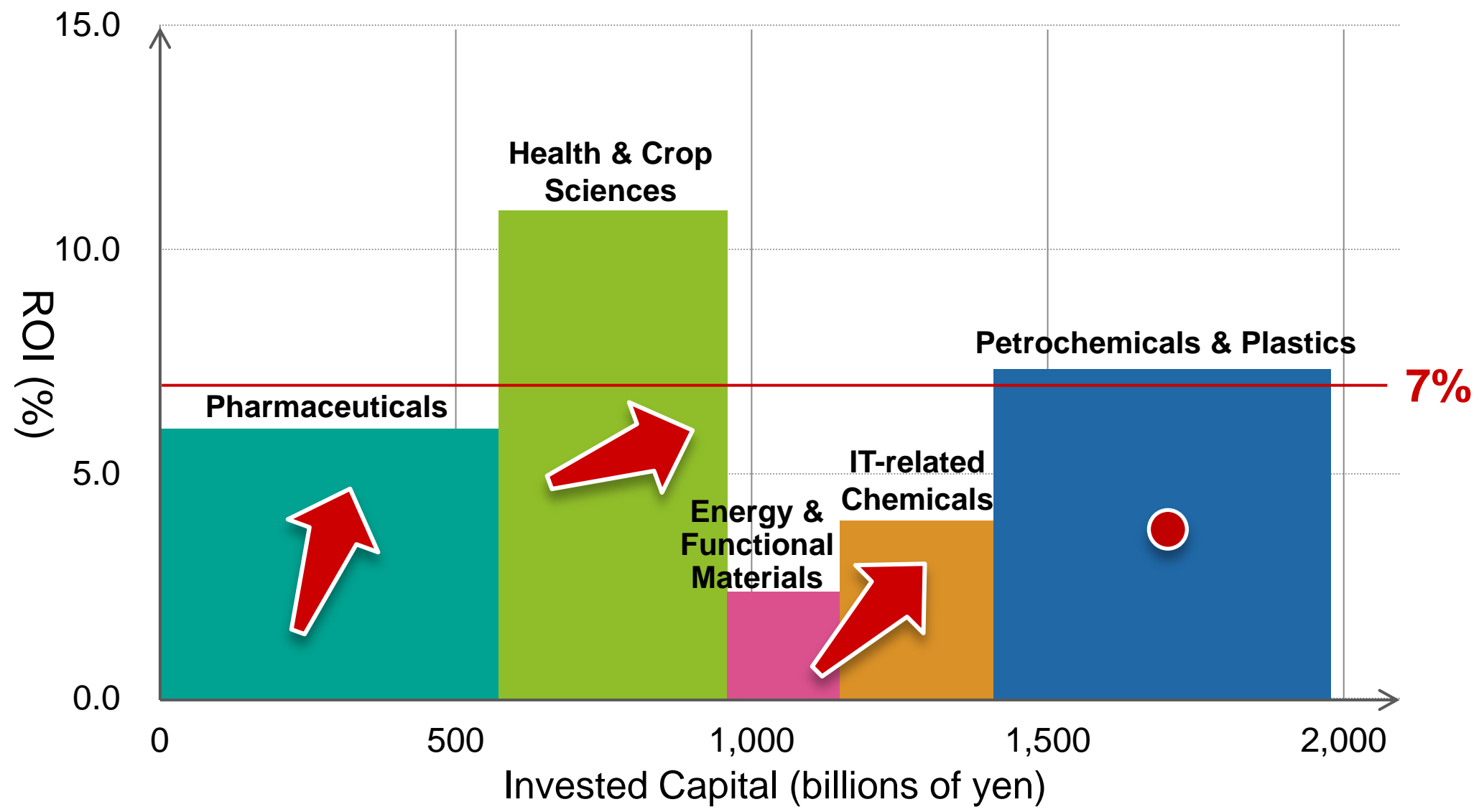

# What Sumitomo Chemical Strives To Be: Ten Years Ahead

## Trend of Ordinary Income

(Billions of yen)

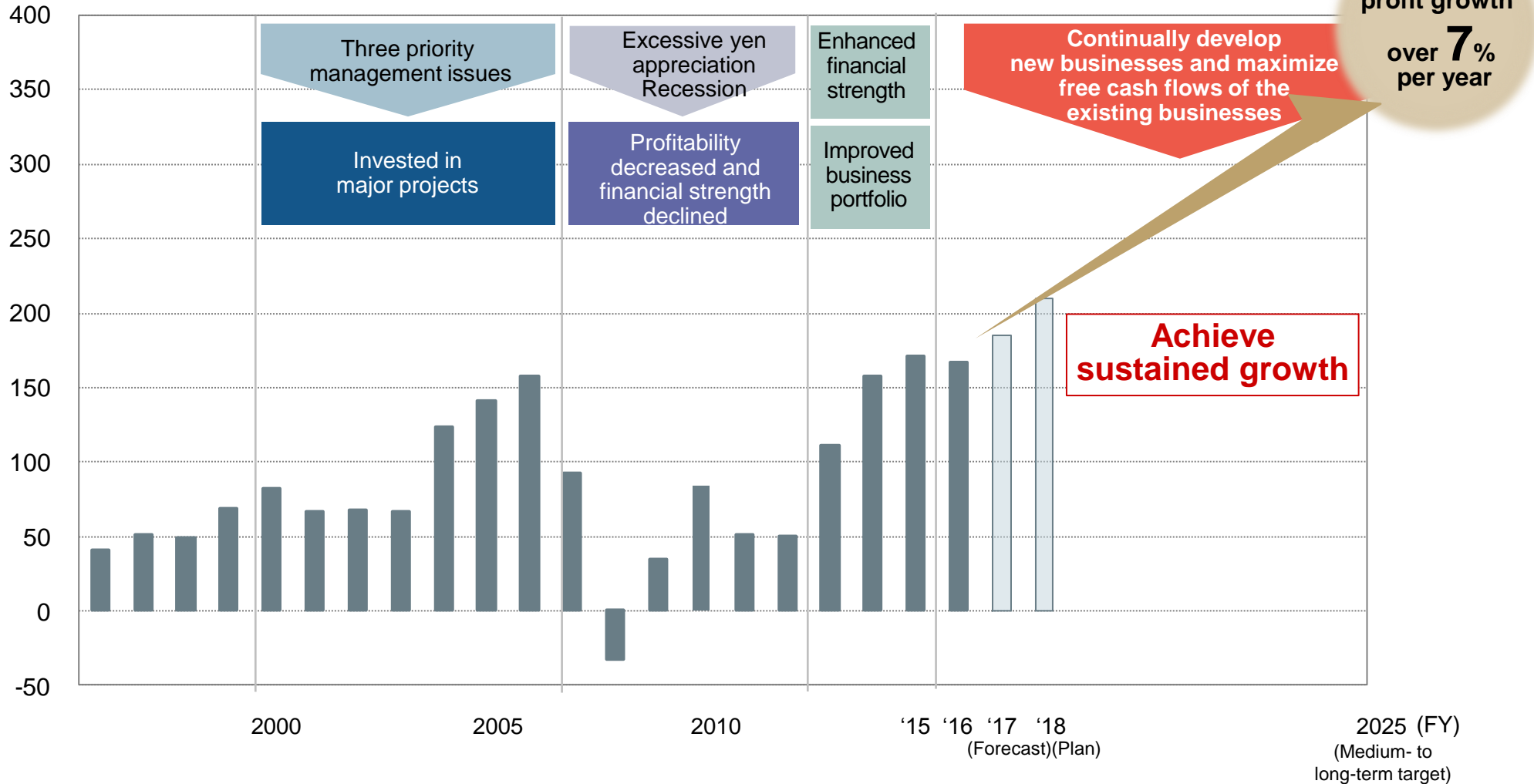

# What Sumitomo Chemical Strives To Be: First Steps Toward Our Goals

## Basic Policy for FY2016-FY2018 Corporate Business Plan

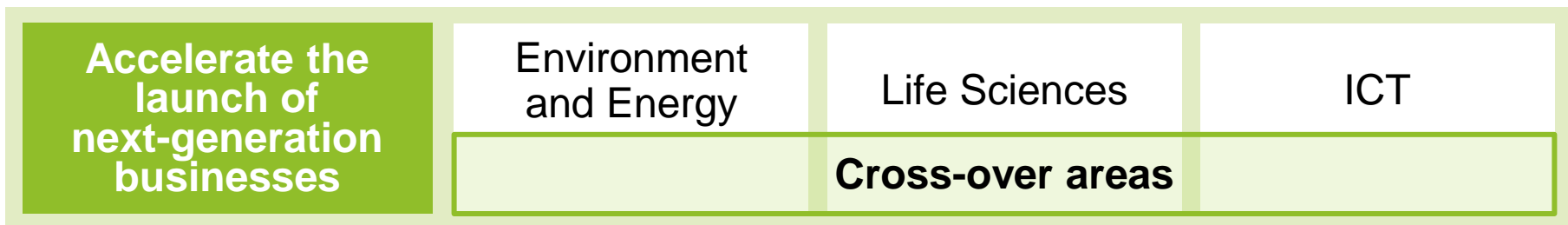
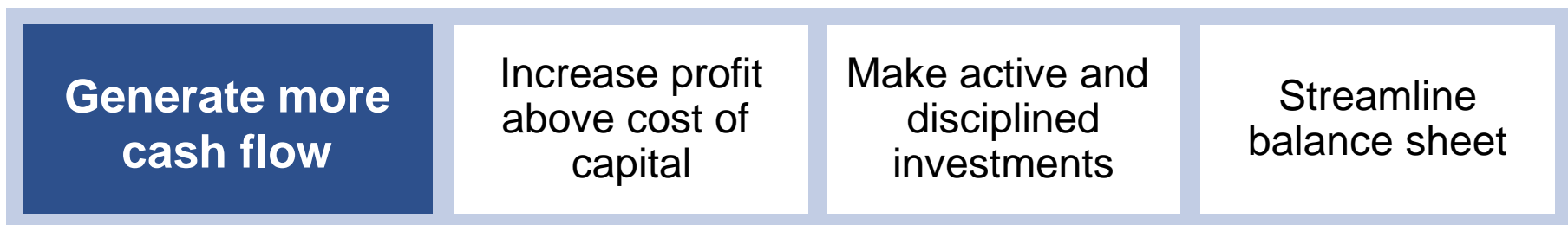
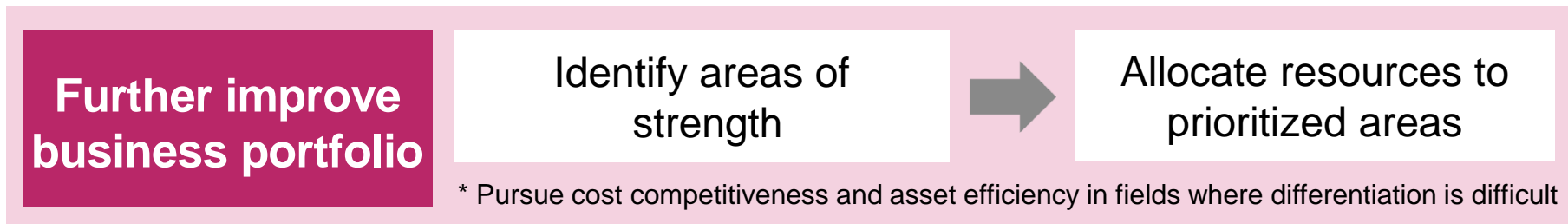

**Promote globally integrated management**

**Ensure full and strict compliance, and establish and maintain safe and stable operations**

## **Progress in Achieving Goals**    **Mainly in Core Businesses**

- **Core Business Trends and Business Strategy**
- **Results for FY2016**

## Progress in Achieving Goals Mainly in Core Businesses

- **Core Business Trends and Business Strategy**
- Results for FY2016

# Health & Crop Sciences: Roadmap Towards Our Goal

## Current Challenges

(Agro Solutions and Environment Health)  
Build a global business foundation  
as a solution provider

## Basic Strategy (Strategic Themes)

- Improve competitiveness of products
- Enhance global footprint
- Strengthen and increase earning power of existing businesses

## Our Long-Term Goal (For Around FY2025)

Contribute to resolving problems facing society\* by  
building on our R&D capabilities

\*global issues related to food, health, hygiene and the environment

FY2016-18  
Business  
Strategy/  
Action Plan

FY2019-  
Business  
Strategy/  
Action Plan



# Health & Crop Sciences: Business Environment

## Food Demand Forecast

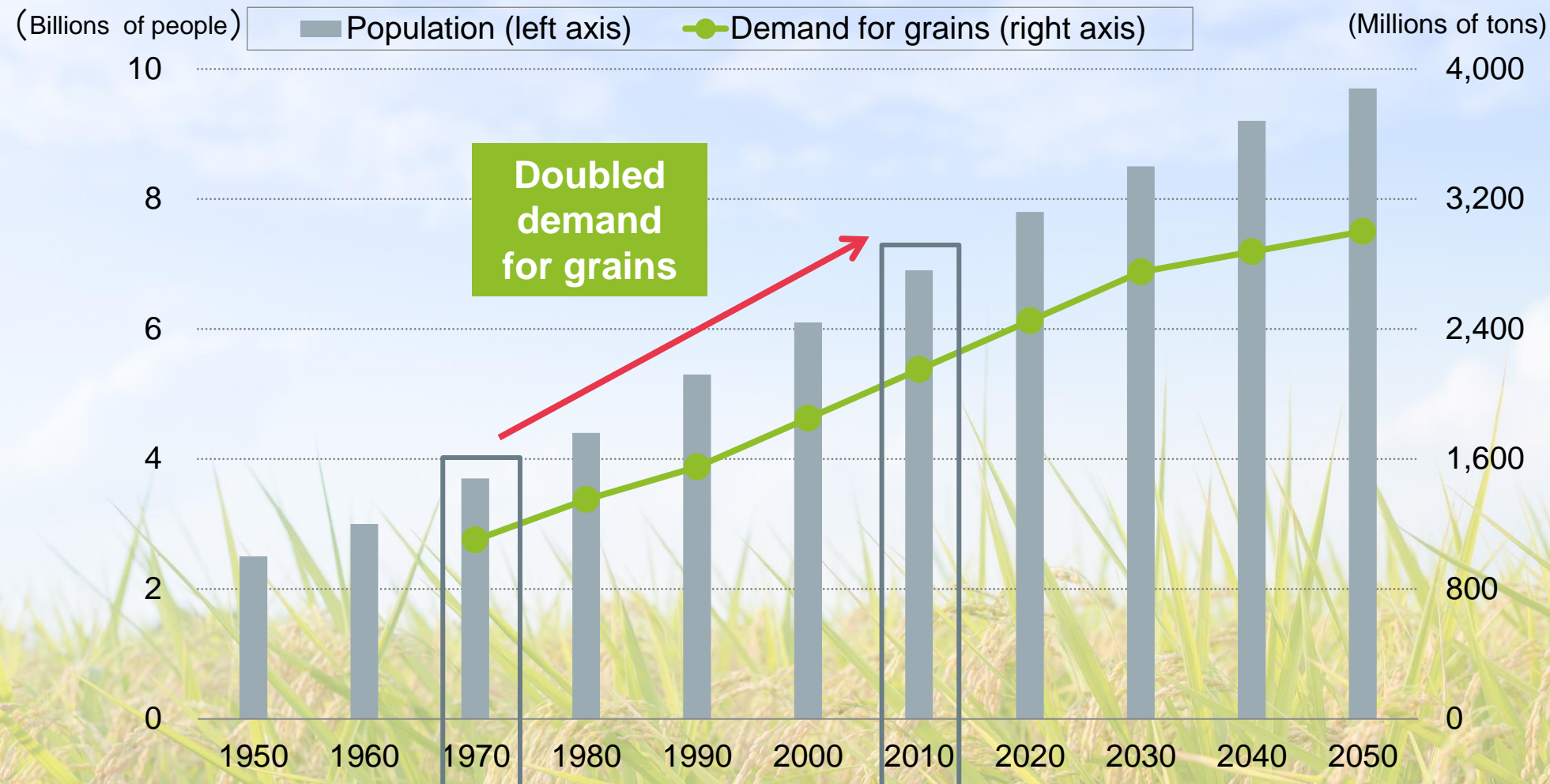

(Source) FAO, "World agriculture: towards 2030/50"; UN Population Fund

# Health & Crop Sciences: Current State of the Crop Protection Chemicals Business

## Crop Protection Product sales by Region

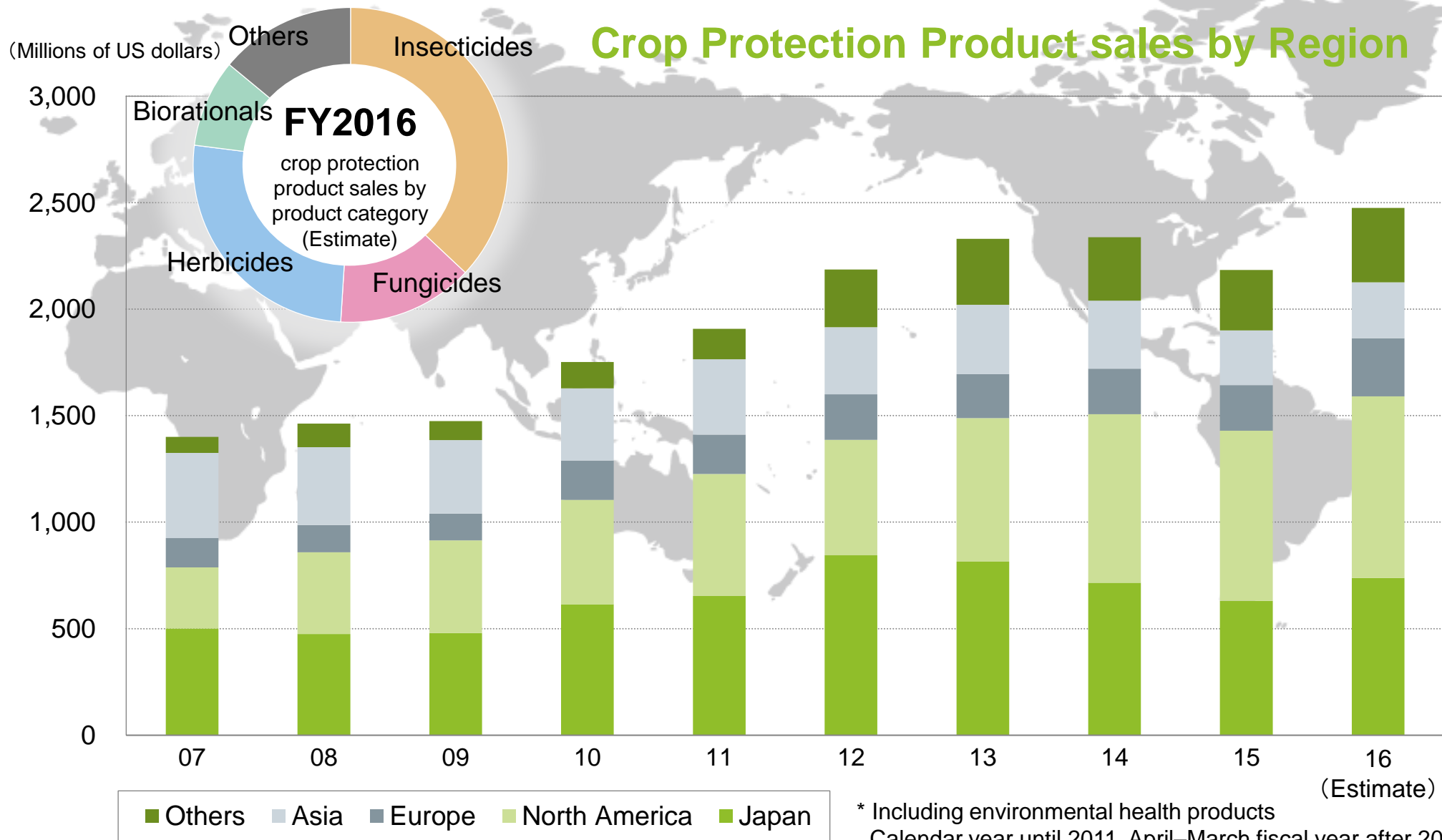

# Health & Crop Sciences: Roadmap Towards Our Goal

## Current Challenges

(Agro Solutions and Environment Health)  
Build a global business foundation  
as a solution provider

## Basic Strategy (Strategic Themes)

- Improve competitiveness of products
- Enhance global footprint
- Strengthen and increase earning power of existing businesses

## Our Long-Term Goal (For Around FY2025)

Contribute to resolving problems  
facing society by building on  
our R&D capabilities

## FY2016-18 Business Strategy/Action Plan

- Accelerate development of next-generation blockbuster crop protection chemicals (B2020/A2020)
- Acquisition of Excel Crop Care
- Enhance synergies of alliances/acquisitions
- Expand business areas  
(expand biorationals/post-harvest, seek synergies for crop protection chemicals and biorationals)
- Expand methionine business

## FY2019- Business Strategy/Action Plan

- Launch/promote sales of next-generation blockbuster crop protection chemicals (B2020/A2020)
- Maximize synergies of alliances/acquisitions
- Explore M&A opportunities
- Expand biorational and crop stress management businesses

# Health & Crop Sciences Sector: Development and Launch of Next-Gen Blockbusters

## Pipeline of New Crop Protection and Household and Public Hygiene Insecticide Products

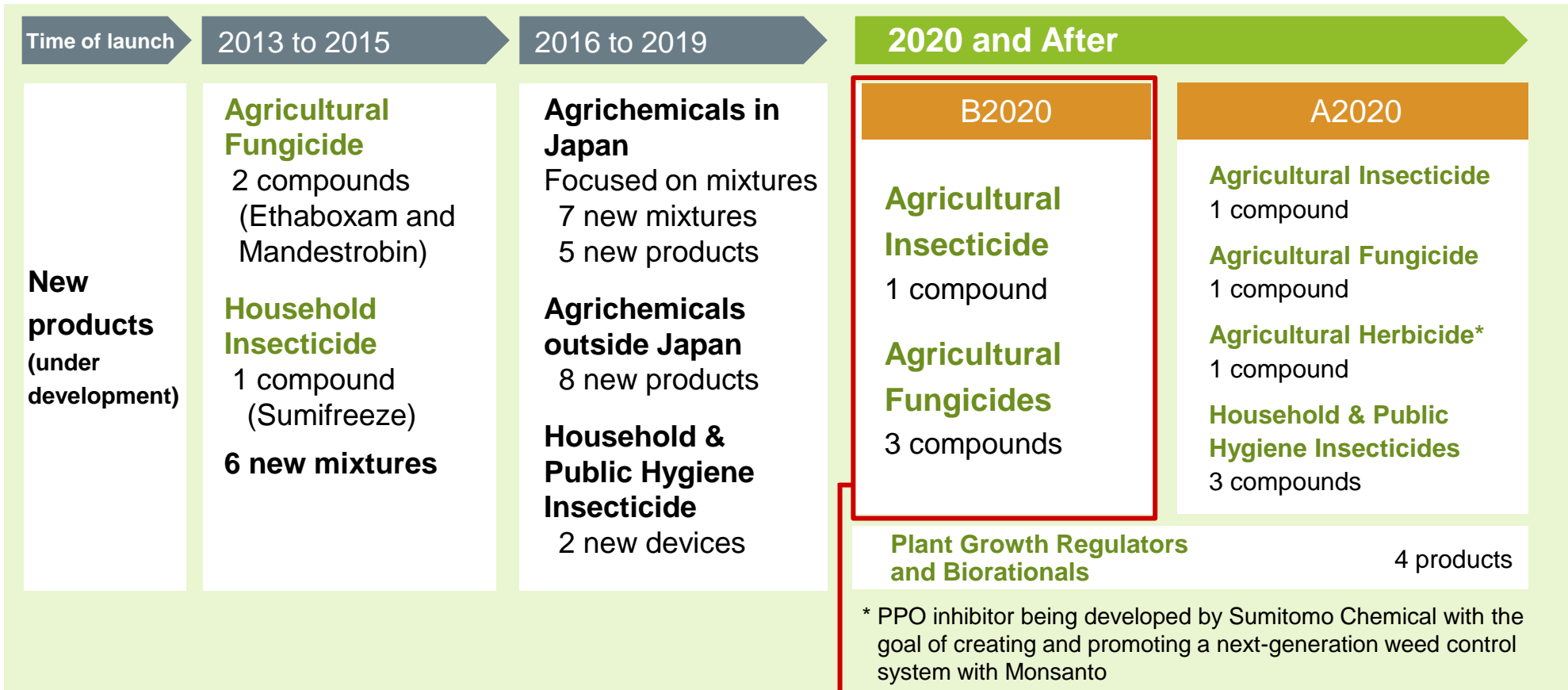

### Expected to grow into blockbusters

- Working to shorten the development period by up to one year
- Future consolidated sales of B2020 products **Over ¥100 billion**

# Health & Crop Sciences Sector: Expand the Scope of Crop Protection Businesses



<b>Seeds</b> • Sunflower • Rapeseed • Sorghum • Rice	<b>Crop protection chemicals</b> • Insecticides and fungicides	<b>Crop protection chemicals</b> • Insecticides, fungicides, and herbicides	<b>Products</b> • Fungicides • Freshness preservers • Coating agents • Plant growth regulators
	<b>Product formulation and application technologies</b> • Insecticides for seed treatment • Plant growth regulators for seed treatment • Seed treatment technology	<b>Biorationals</b> • Microbial pesticides • Plant growth regulators • Microbial agricultural materials	<b>Services</b> • Post-harvest treatment • Pre-shipment treatment • Residue analysis
		<b>Fertilizers</b> • Coated fertilizers	
		<b>Product formulation technology</b> • Microcapsule	

Targeted business areas for expansion

## Expansion of targeted businesses

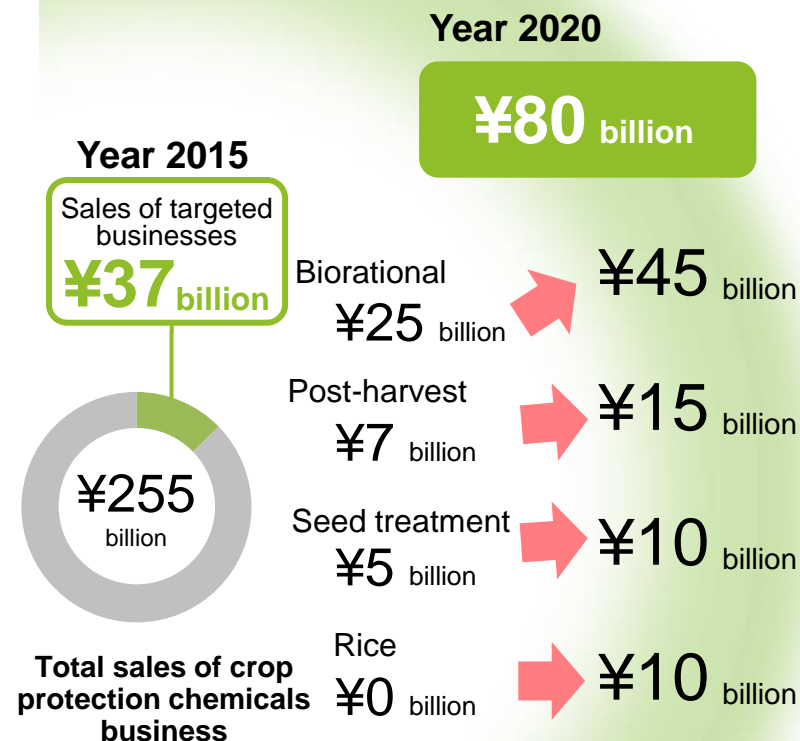

# Pharmaceuticals: Roadmap Towards Our Goal

## Current Challenges

- Address the Latuda patent cliff
- Develop next-generation pharmaceuticals

## Basic Strategy (Strategic Themes)

- Address patent cliff
- Develop next-generation pharmaceuticals
- Strengthen cost competitiveness

## Our Long-Term Goal (For Around FY2025)

- Focus on the areas of psychiatric and neurological disorders and cancer/regenerative and cellular medicine
- Become an R&D-driver company that can compete globally

FY2016-18  
Business  
Strategy/  
Action Plan

FY2019-  
Business  
Strategy/  
Action Plan

# Pharmaceuticals: Business Trends

## Early Recovery from LATUDA Patent Cliff

While revenues are expected to decline for FY2019 because of the expiration of US patent for LATUDA, we aim to achieve speedy recovery in and after FY2020 by launching and expanding sales of products currently in late stages of development

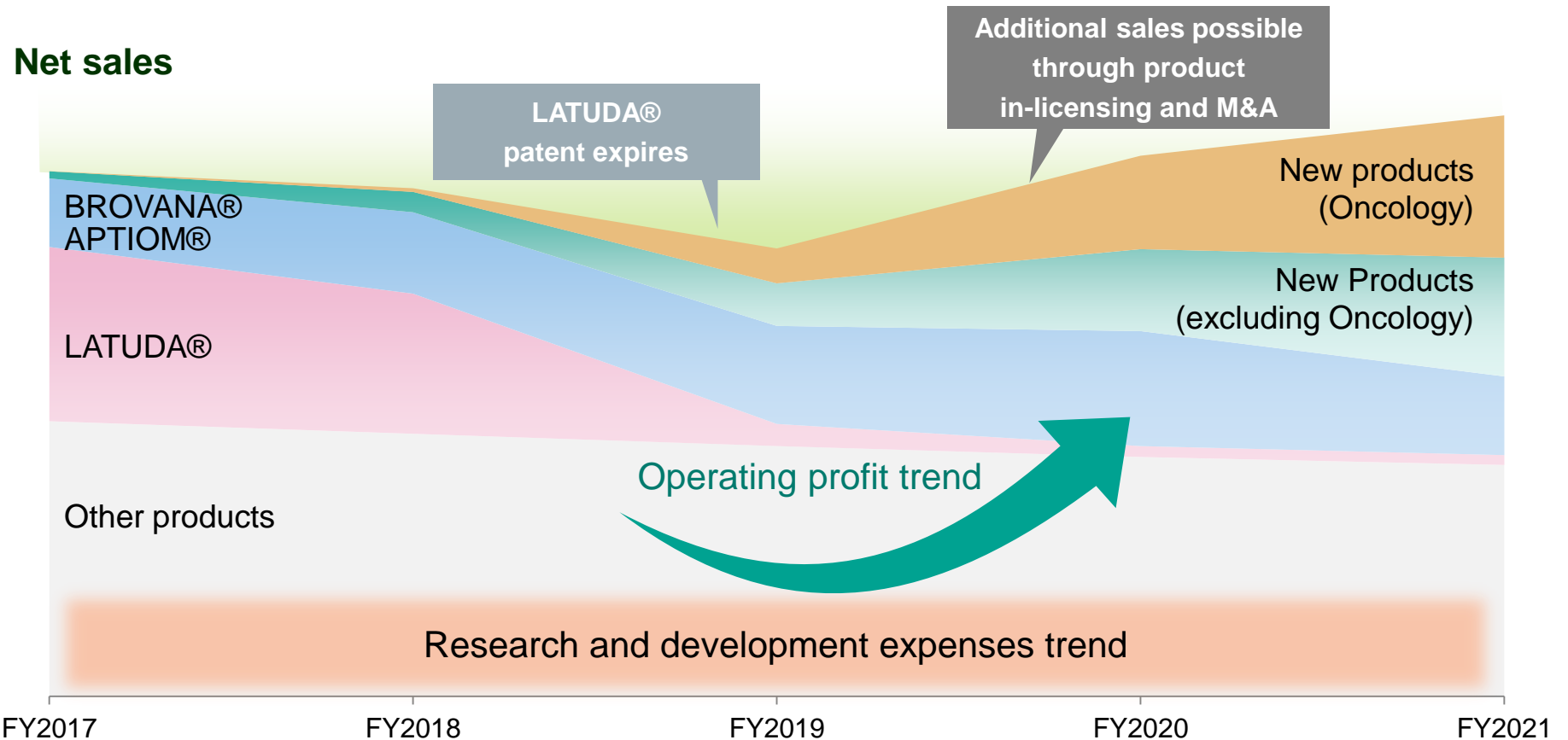

(created on May 2016)

# Pharmaceuticals: Roadmap Towards Our Goal

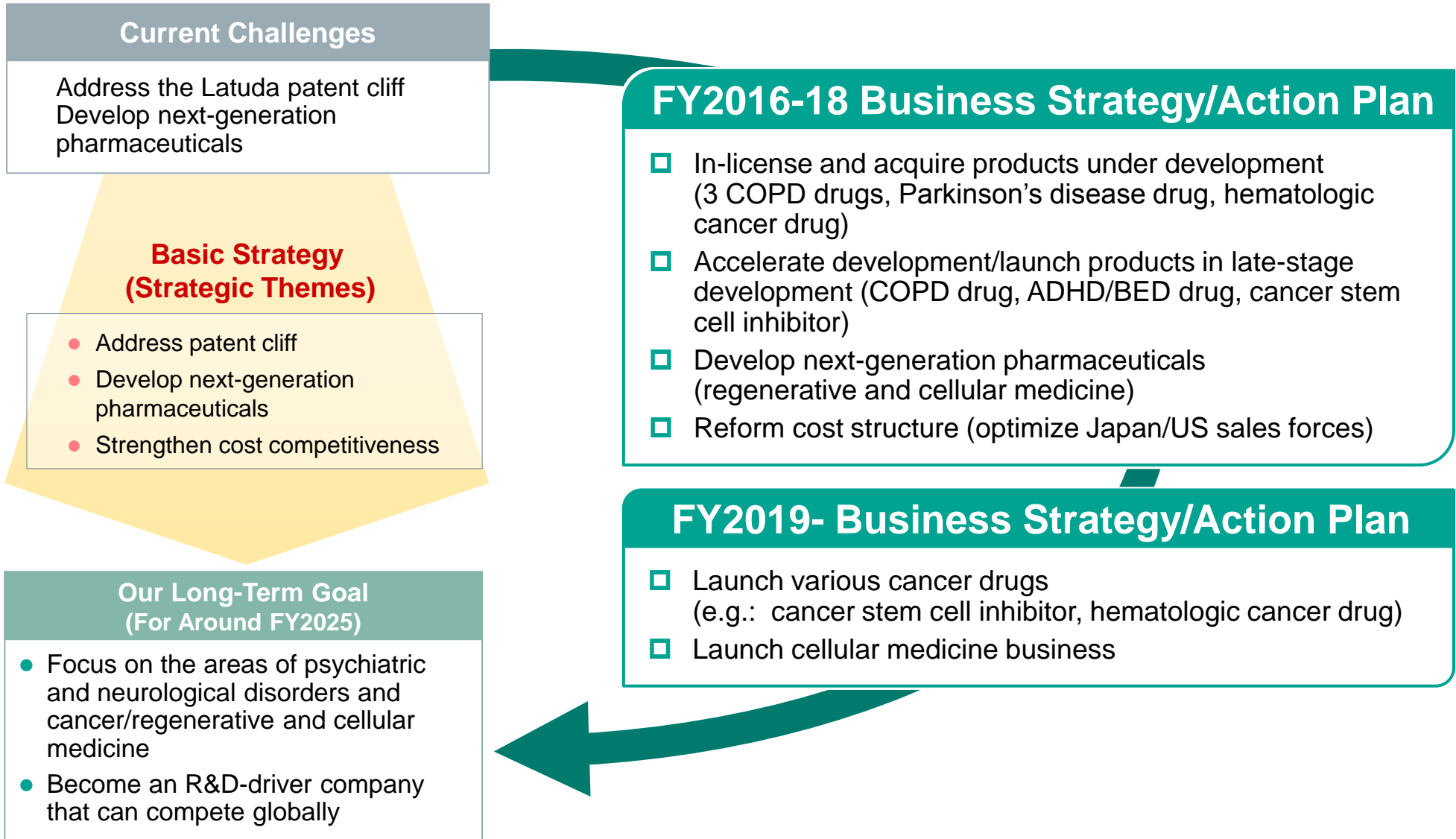



# Pharmaceuticals Sector: Launch and Development of Major Products

## Introducing 3 COPD Treatments\*<sup>1</sup>

### Indications

Chronic obstructive pulmonary disease (COPD)

### Features

Can provide a wide range of treatment options

### Development and Launch Schedule

2012: ARCAPTA (US)<sup>\*2</sup>  
 April 2017: UTIBRON (US)  
 During FY2017: SEEBRI (US)  
 SUN-101 (US)<sup>\*3</sup>

\*1 Introducing 3 COPD Treatments:  
 Signed a license agreement with Novartis for  
 3 COPD treatments in the US in December 2016

\*2 Promotion by Sumitomo Chemical to begin in FY2017

\*3 Applied for approval in U.S.

**Expected peak sales about 50 billion yen**

## ADHD/BED Treatment\*

### Indication

Attention deficit hyperactivity disorder (ADHD)/  
 Binge eating disorder (BED)

### Features

Long half-life  
 (24 hour dosage interval)

### Development and Launch Schedule

Current: Phase III clinical trials completed for  
 adult and pediatric ADHD (U.S.)  
 In phase III clinical trials for BED (U.S.)

FY2018: Planned launch for ADHD (U.S.)

FY2019: Planned launch for BED (U.S.)

\* Dasotraline

**Expected peak sales about 50 billion yen**

**Making progress in new product development and in-licensing for post-LATUDA period**

# Pharmaceuticals Sector: Major Products Under Development

## Acquisition of Parkinson's disease treatment\*

### Indications

"Off" episodes of Parkinson's disease

### Features

Sublingual thin film

### Development and Launch Schedule

At present: In phase III clinical trials (U.S.)

FY2017: Submit new drug application

FY2018: Planned launch



Administration of APL-130277

\* Acquired in the acquisition of Cynapsus Therapeutics Inc. in October 2016 for 635 million dollars

**Expected peak sales about 50 billion yen**

## Acquisition of hematologic cancer treatment\*

### Indications

Hematologic cancer

### Features

Cyclin-dependent kinase 9 (CDK9) inhibitor (injected)

### Development and Launch Schedule

At present:

In Phase II clinical trials (U.S.) (Acute myeloid leukemia)

FY2019: Planned launch

\* Acquisition of hematologic cancer treatment:

In the acquisition of Tolero Pharmaceuticals in January 2017, we gained 6 compounds including alvocidib, a hematologic cancer treatment, for an upfront payment of \$200 million, a development milestone payment of \$430 million (max) and a sales milestones payment of \$150 million (max)

**Expected peak sales about 50 billion yen**

**Making progress in new product development and in-licensing for post-LATUDA period**

# Pharmaceuticals Sector: Regenerative Medicine and Cell Therapy

## Regenerative Medicine and Cell Therapy Development Plan

	Partnering	Region (planned)	Cell type	Development schedule (calendar year)				
				2017	2018	2019	2020~22	
Chronic stroke (SB623)	SanBio	North America	Allogeneic MSC	Ph-IIb			Approval target	
						Ph-III		
Age-related macular degeneration	Healios RIKEN	Japan	Allogeneic iPS cell	Clinical research	Investigator or corporate initiated clinical trial*			Approval target
Parkinson's disease	Kyoto University CiRA	Global	Allogeneic iPS cell		Investigator initiated clinical trial			
Retinitis pigmentosa	RIKEN	Global	Allogeneic iPS cell		Clinical research			
Spinal cord injury	Keio University Osaka National Hospital	Global	Allogeneic iPS cell		Clinical research			

\* Start of clinical studies originally scheduled for 2017 is expected to be delayed due to changes in non-clinical study plans.

**Planning to start the operation of cell processing center in FY 2017**

# Energy & Functional Materials Sector: Roadmap Towards Our Goal

## Current Challenges

- Review of business portfolio
- Build foundation for growth

## Basic Strategy (Strategic Themes)

- Select and foster growth businesses
- Restructure underperforming businesses

## Our Long-Term Goal (For Around FY2025)

Contribute to resolving environmental/energy issues through innovative technology

**FY2016-18  
Business  
Strategy/  
Action Plan**

**FY2019-  
Business  
Strategy/  
Action Plan**

# Energy & Functional Materials: Business Trends

## Market for Lithium-Ion Secondary Batteries for Automotive Use

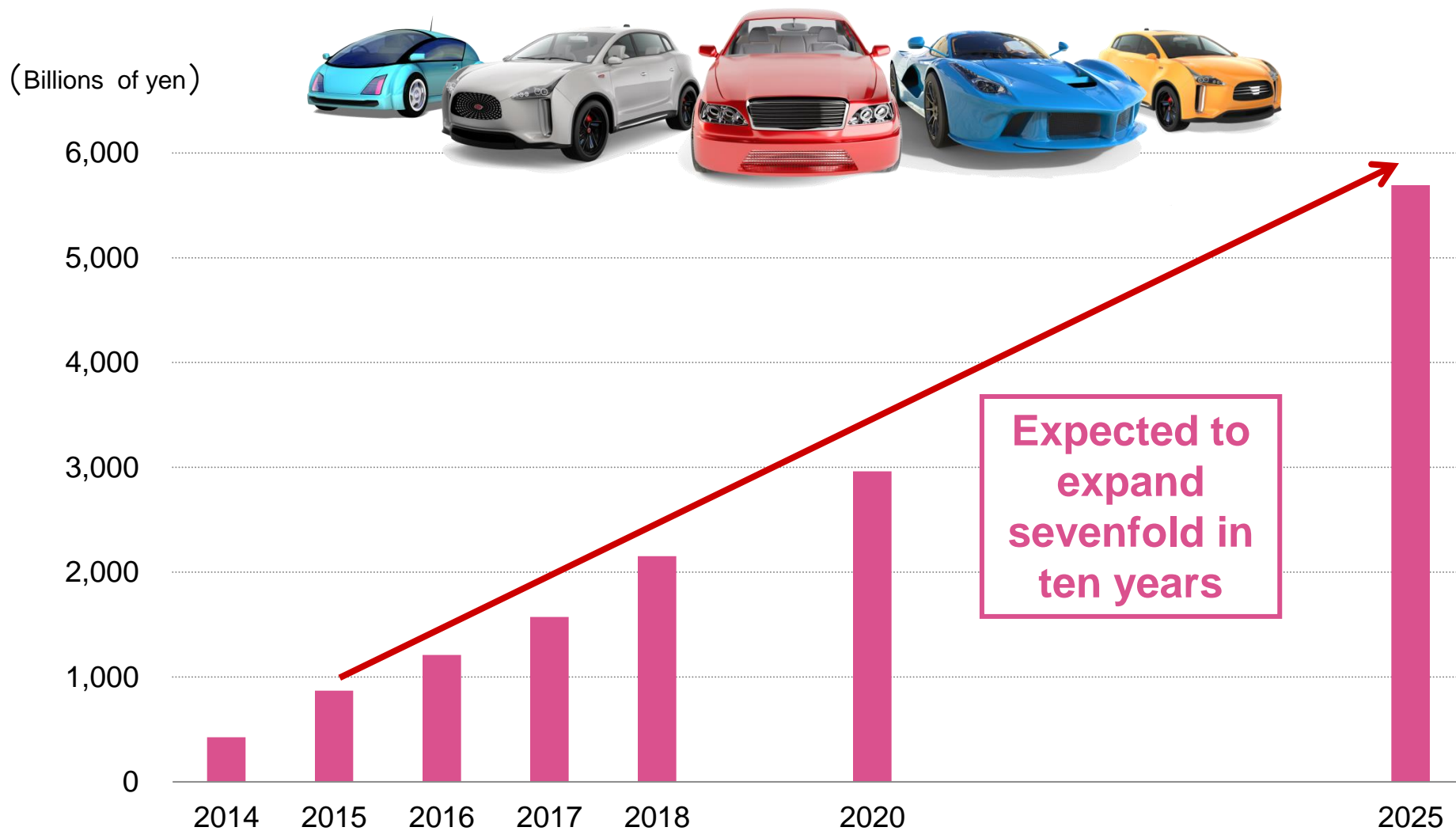

(Source) "Future Outlook of Energy, Large Scale Secondary Battery, and Materials 2016; Energy Devices" by Fuji Keizai

# Energy & Functional Materials: Current State of Battery Materials Business

## Market of 4 major components and materials for lithium-ion secondary batteries

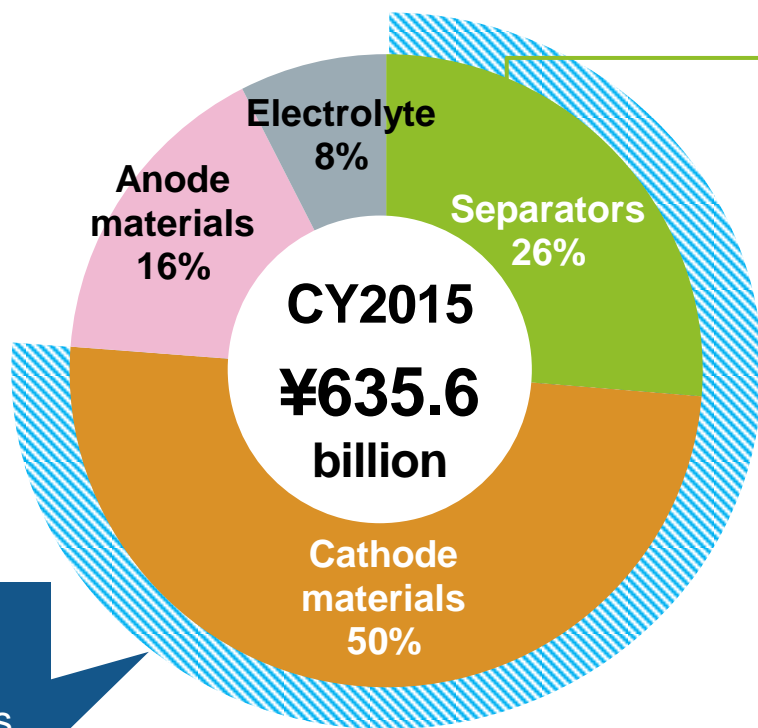

Sumitomo Chemical's target markets  
**76%**

### Our products



### Panasonic and others



(Source) “Future Outlook of Energy, Large Scale Secondary Battery, and Materials 2016; Energy Devices” by Fuji Keizai

# Energy & Functional Materials Sector: Roadmap Towards Our Goal

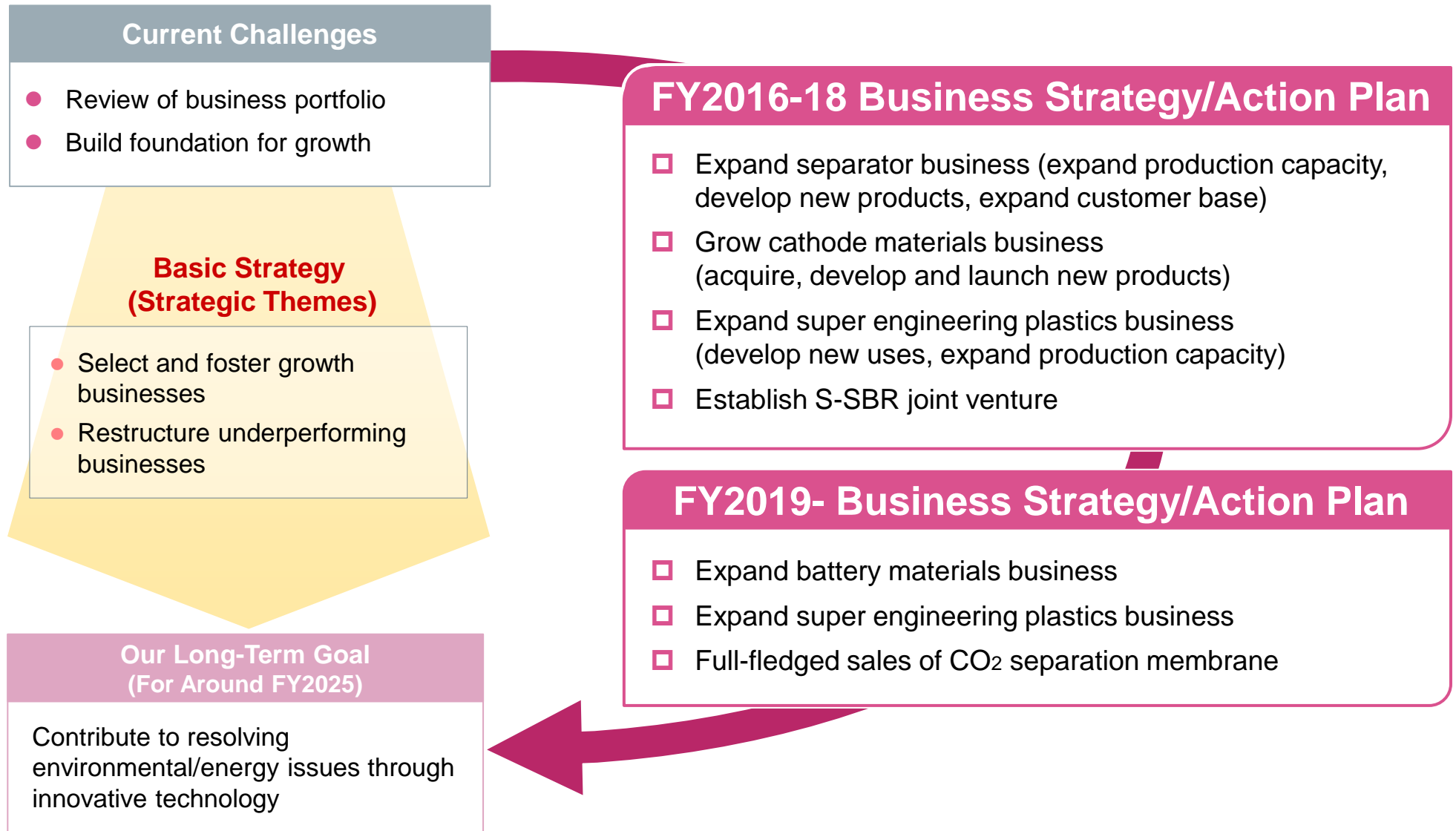

# Energy & Functional Materials Sector: Decided to Increase Lithium-Ion Secondary Battery Separator Production Capacity

## Eco-car market trends

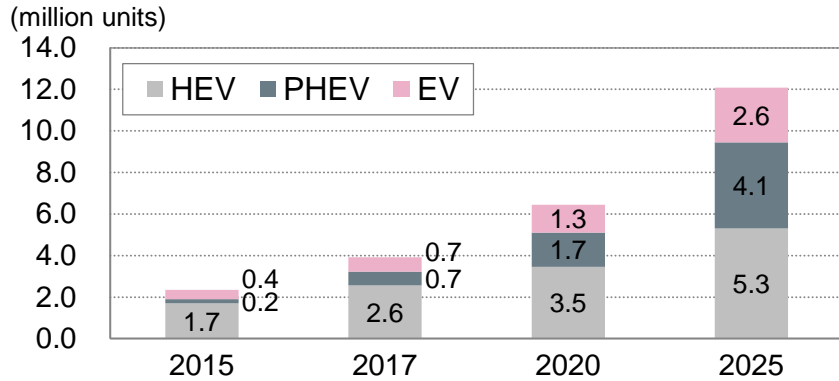

(Source) "Future Outlook of Energy, Large Scale Secondary Batteries, and Materials 2016; Energy Devices" by Fuji Keizai

## Market outlook for lithium-ion secondary batteries and components and materials

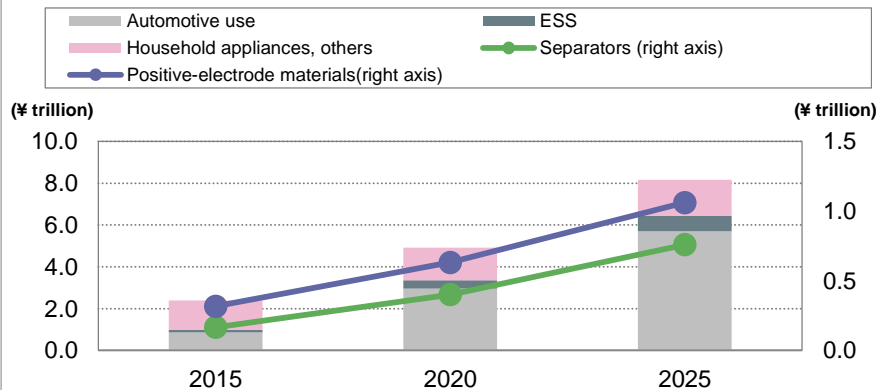

(Source) "Future Outlook of Energy, Large Scale Secondary Batteries, and Materials 2016; Energy Devices" by Fuji Keizai

## Advantages of aramid-coated separators

High heat resistance,  
greater safety

Lightweight

Less  
powder dust

Best suited for high-capacity batteries for  
automotive and other applications

Increasing demand for use in eco-friendly cars

## Separator production capacity expansion plan

**Production capacity:** South Korea production capacity to be quadrupled

**Start of operations:** In stages from August 2017



Separators

Separator  
production capacity

	Future
Japan	Approx. 100 million m <sup>2</sup>
South Korea	Approx. 300 million m <sup>2</sup>
Total	Approx. 400 million m <sup>2</sup>

4  
times

**Expand market share of lithium-ion secondary battery separator for automotive use**



# Energy & Functional Materials: Development of Automotive Applications for SEP

## Features of Sumitomo Chemical's SEPs

LCP	PES
<ul style="list-style-type: none"> <li>• High strength and stiffness</li> <li>• Heat resistant</li> <li>• High liquidity</li> <li>• High dimensional accuracy</li> <li>• Flame retardant</li> </ul>	<ul style="list-style-type: none"> <li>• Heat resistant</li> <li>• High creep resistance</li> <li>• Dimensional stability</li> <li>• Flame retardant</li> <li>• Hydrolysis resistance</li> </ul>

LCP: Liquid crystal polymer    PES: Polyethersulfone

## Long Fiber Compound Technology Development

- Similar stiffness to metal
  - Freedom in component design
  - Reduced component numbers due to one-piece casting
- } Possible

## SEP for Automotive Use

- 1** Engine, HEV/EV and transmission components

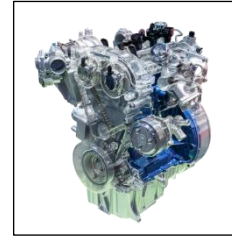

- 4** External panel components



- 2** Headlight components

- 3** Electrical components (e.g., relays)

**SEP is expected to replace metal for light weight and also to be used in new applications that will emerge due to the advance of automatic driving technology and increased use of electrical and electronic components and systems in cars.**

# IT-Related Chemicals: Roadmap Towards Our Goal

## Current Challenges

Address the generational shift in display technology from LCD to OLED

## Basic Strategy (Strategic Themes)

- Expand OLED materials and components business
- Improve cost structure of LCD materials and components business
- Explore and develop next-generation businesses

## Our Long-Term Goal (For Around FY2025)

Provide new materials/solutions that promote the advance of the ICT industry

FY2016-18  
Business  
Strategy/  
Action Plan

FY2019-  
Business  
Strategy/  
Action Plan

# IT-Related Chemicals: TV Display Market Trends

## Supply Capacity for LCD panels for TVs by Country

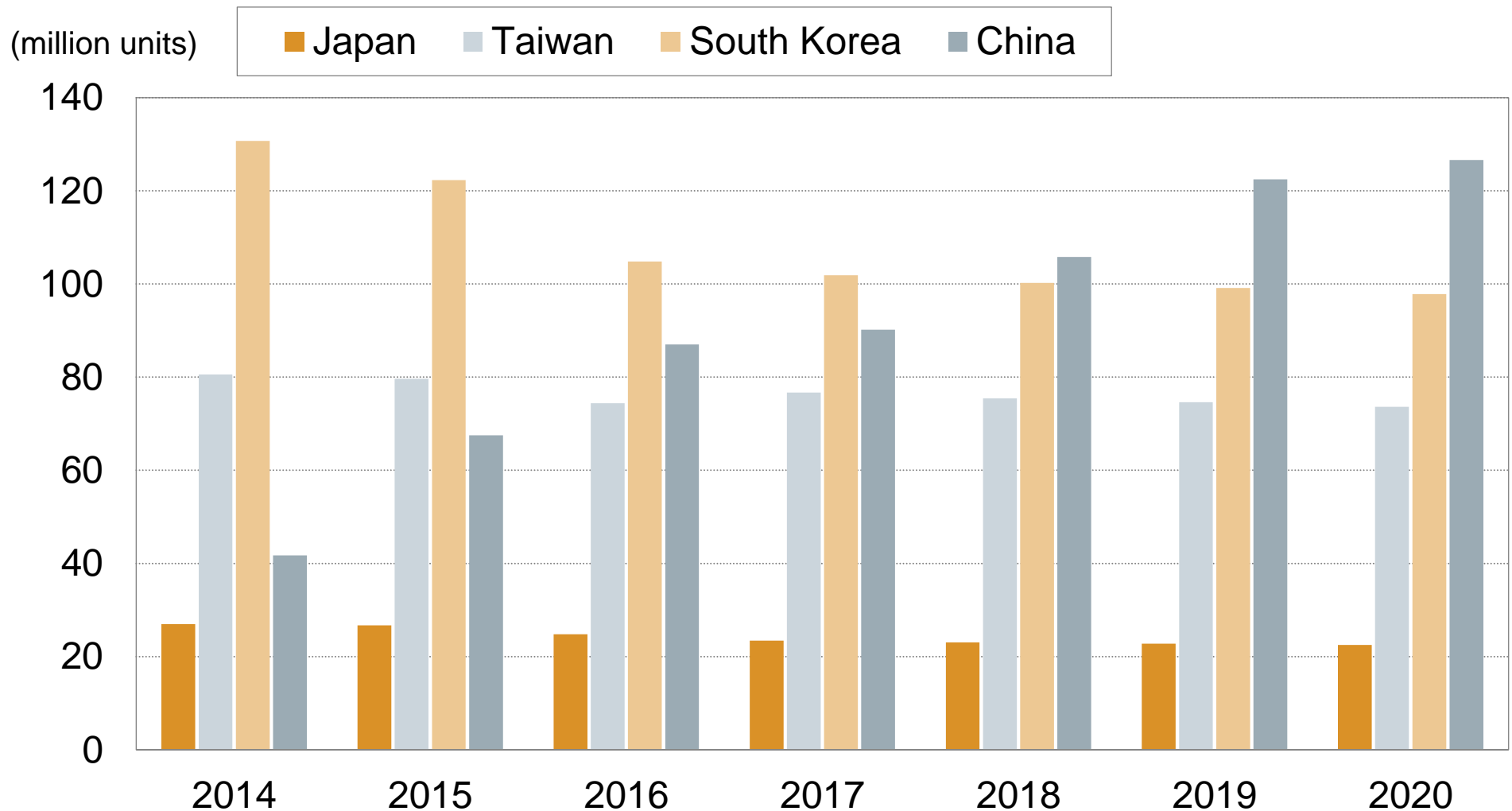

(Source) IHS Markit Technology

# IT-Related Chemicals: Market Trends of Displays for Mobile Devices

## Shipment of Smartphone Displays by Type

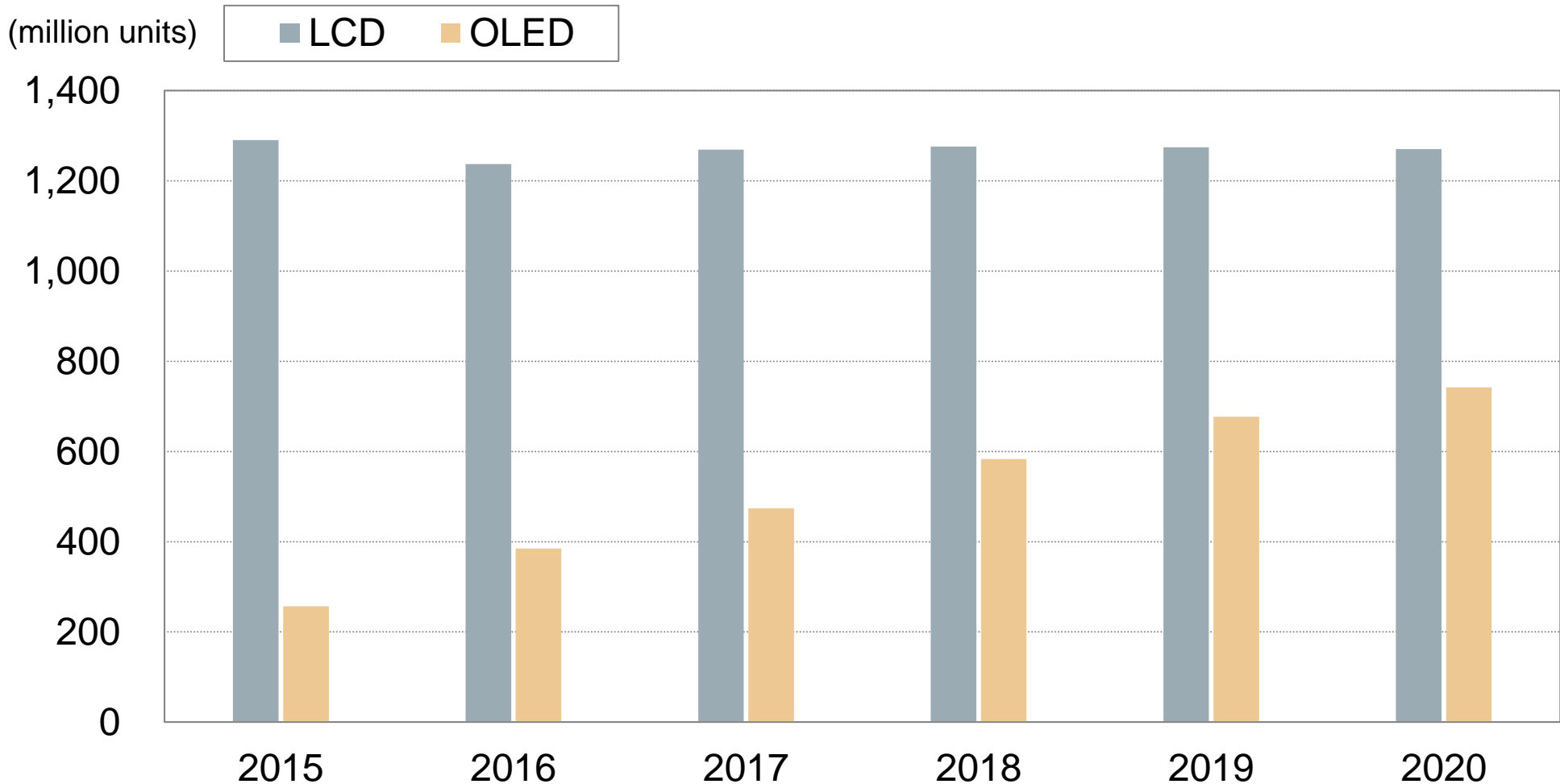

(Source) IHS Markit Technology

# IT-Related Chemicals: Roadmap Towards Our Goal

## Current Challenges

Address the generational shift in display technology

## Basic Strategy (Strategic Themes)

- Expand OLED materials and components business
- Improve cost structure of LCD materials and components business
- Explore and develop next-generation businesses

## Our Long-Term Goal (For Around FY2025)

Provide new materials/solutions that promote the advance of the ICT industry

## FY2016-18 Business Strategy/Action Plan

- Expand touchscreen panel business (expand product lineup, strengthen production capacity, expand customer base)
- Launch flexible display materials business
- Launch PLED business
- Restructure LCD materials and components business (restructure production capabilities increase cost reduction effort)

## FY2019- Business Strategy/Action Plan

- Expand flexible display materials business (launch multi-functional materials and components, etc.)
- Expand PLED business
- Maximize cash flow of LCD materials and components business

# IT-related Chemicals: Business Life Cycle Management in ICT Area

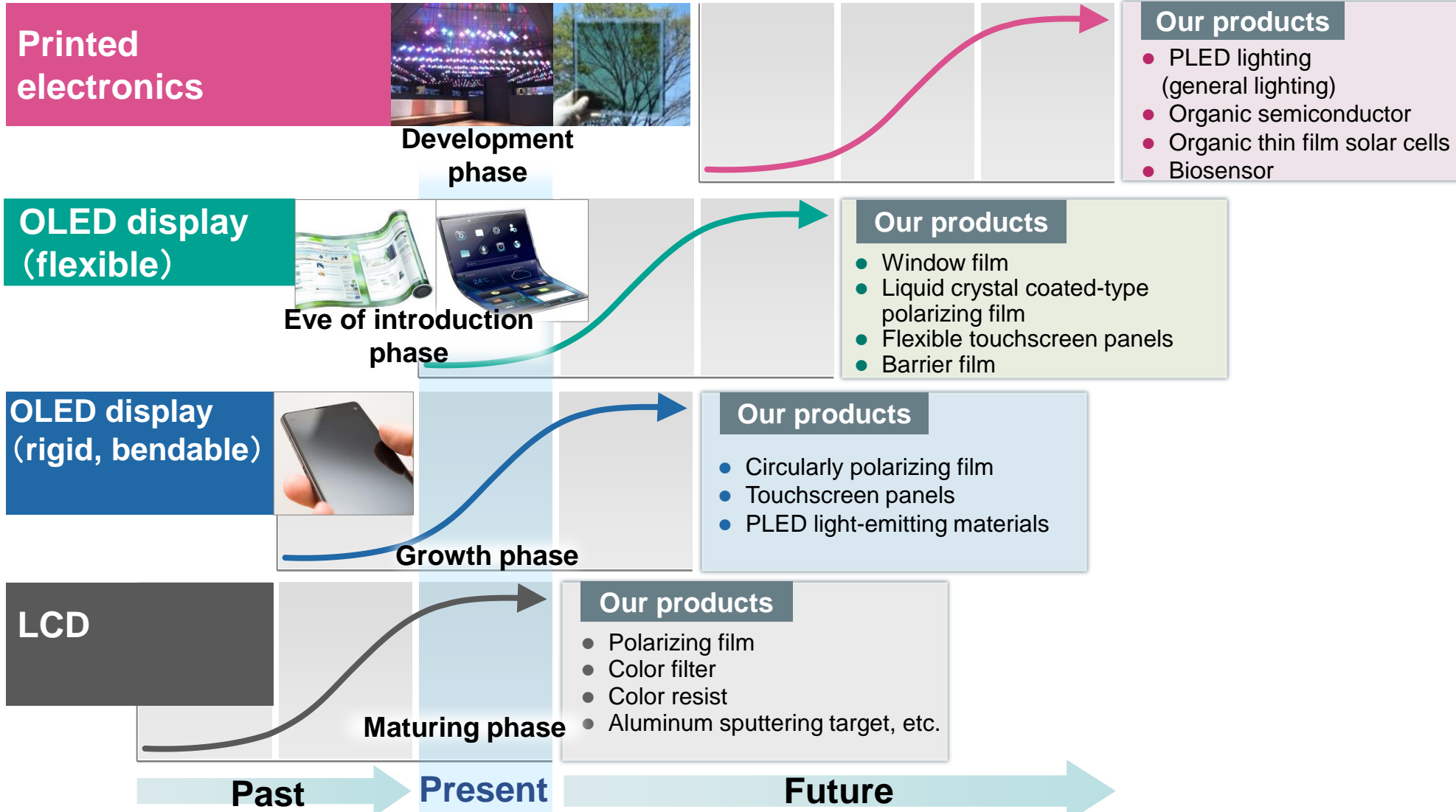

**Develop the next-generation business pipeline in anticipation of generational shift in display technology**

## Sumitomo Chemical's OLED-related materials

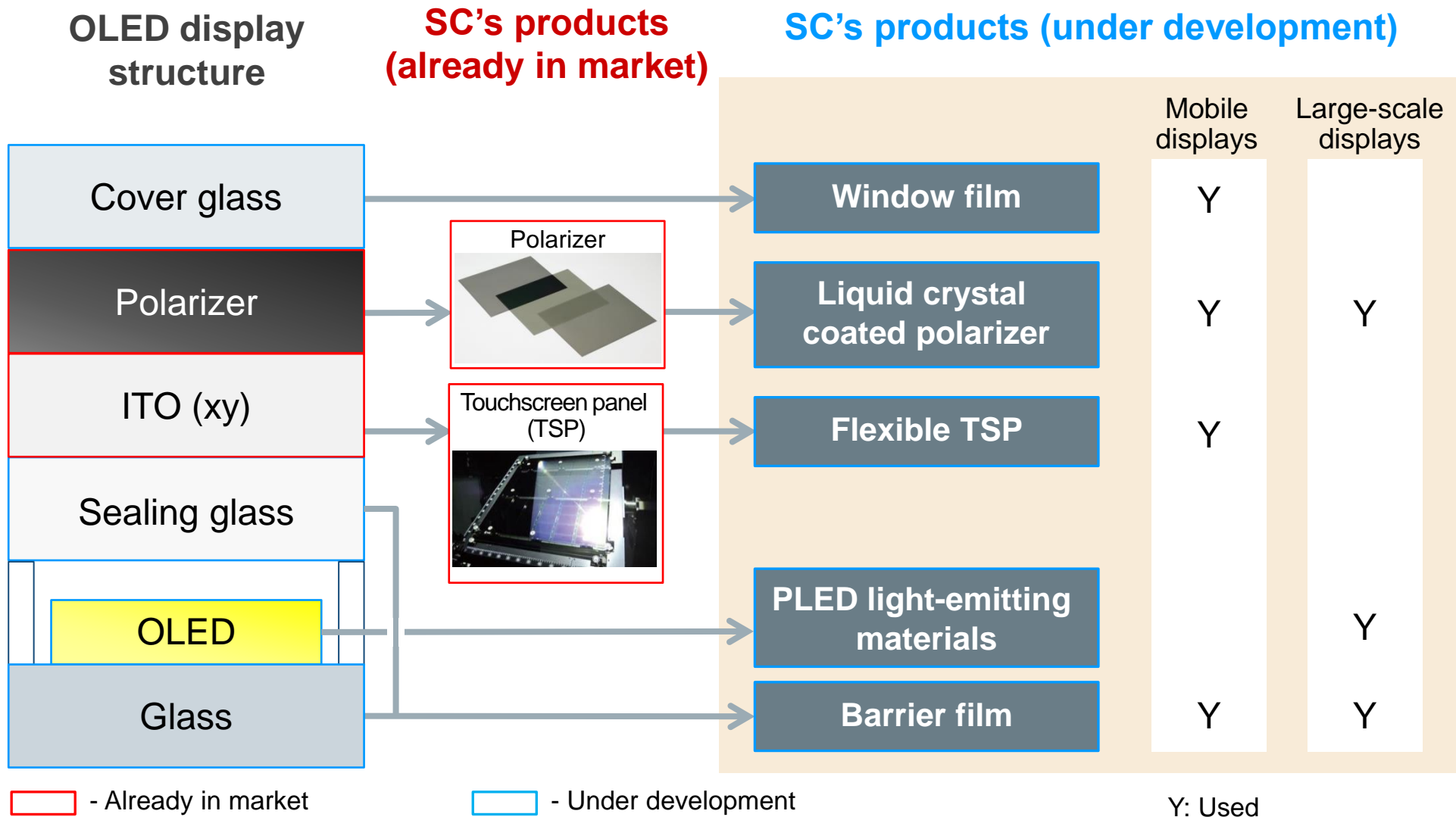

# IT-related Chemicals: Business Strategy Going Forward

## Composition of display materials and components sales

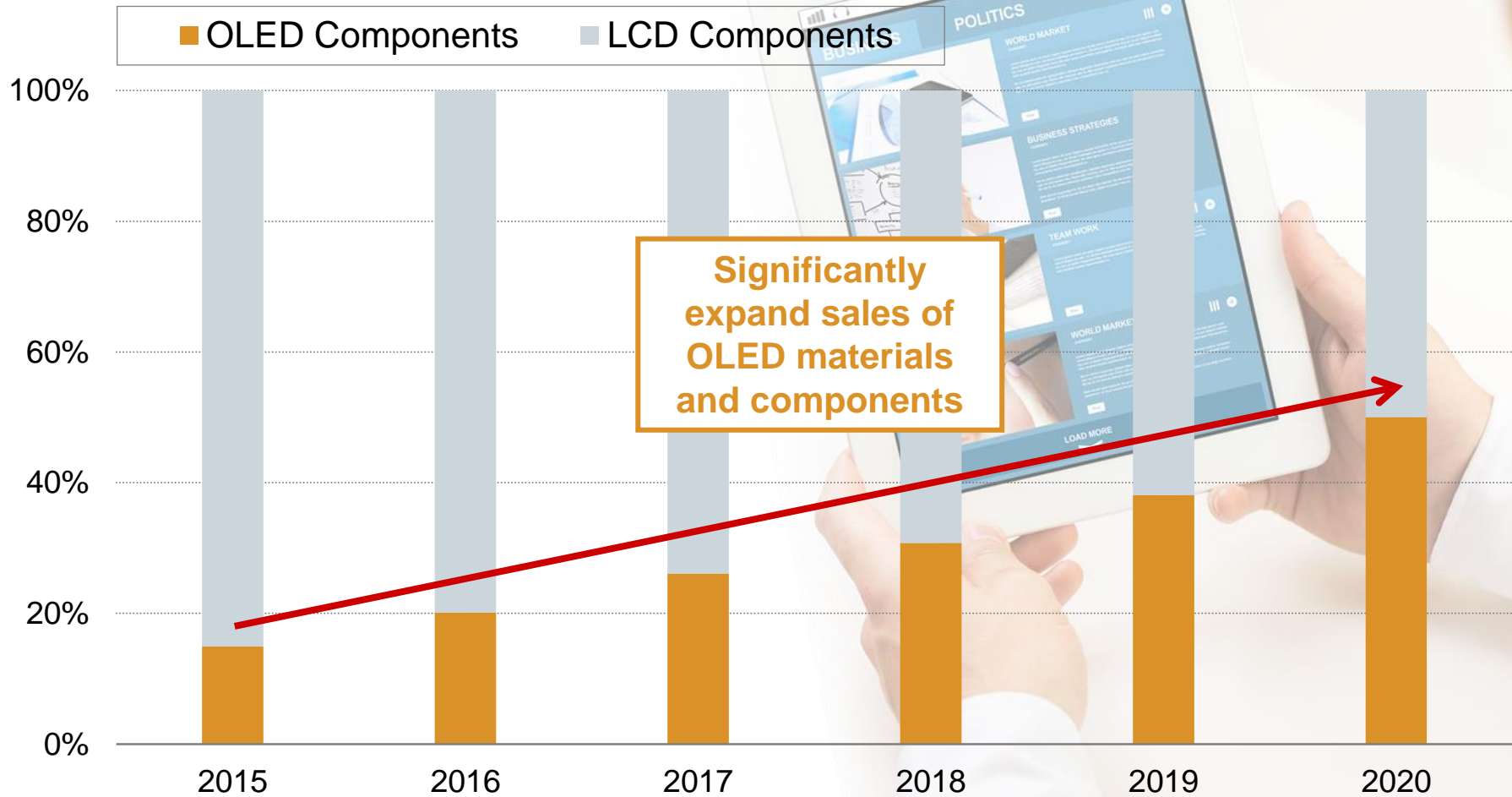



# Petrochemicals & Plastics: Roadmap Towards Our Goal

## Current Challenges

- Maintain a high operating rate at Petro Rabigh
- Enhance high value-added business in Singapore

## Basic Strategy (Strategic Themes)

- Enhance high value-added business
- Stabilize operations at Petro Rabigh
- Restructure businesses

## Our Long-Term Goal (For Around FY2025)

- Provide solutions through high value-added products
- Maintain stable supply of cost-competitive general-purpose products

**FY2016-18  
Business  
Strategy/  
Action Plan**

**FY2019-  
Business  
Strategy/  
Action Plan**

# Petrochemicals & Plastics: World's Ethylene Production by Feedstock

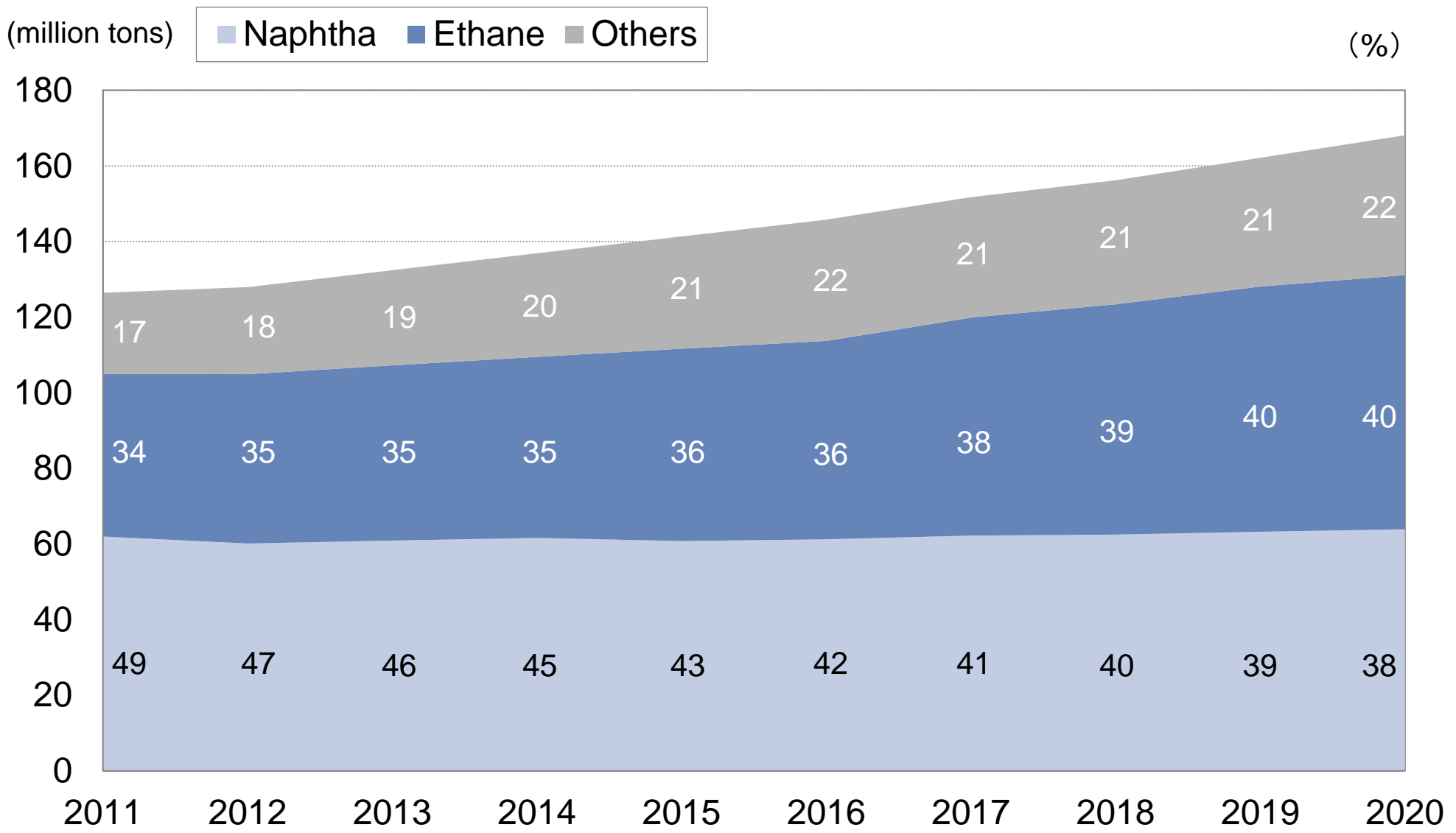

(Source) The Chemical Daily

# Petrochemicals & Plastics: Roadmap Towards Our Goal

## Current Challenges

- Maintain a high operating rate at Petro Rabigh
- Enhance high value-added business in Singapore

## Basic Strategy (Strategic Themes)

- Enhance high value-added business
- Stabilize operations at Petro Rabigh
- Restructure businesses

## Our Long-Term Goal (For Around FY2025)

- Provide solutions through high value-added products
- Maintain stable supply of cost-competitive general-purpose products

## FY2016-18 Business Strategy/Action Plan

- ▣ Enhance high value-added business (modify TPC's production facilities, develop and launch new products)
- ▣ Rabigh Phase I project: Stable operations
- ▣ Rabigh Phase II project: Construction and start operations
- ▣ Restructure businesses

## FY2019- Business Strategy/Action Plan

- ▣ Enhance high value-added business (Singapore, Japan)
- ▣ Stabilize operations (Rabigh Phase I and Phase II projects)

# Petrochemicals & Plastics: TPC Shift to High Value-added Products

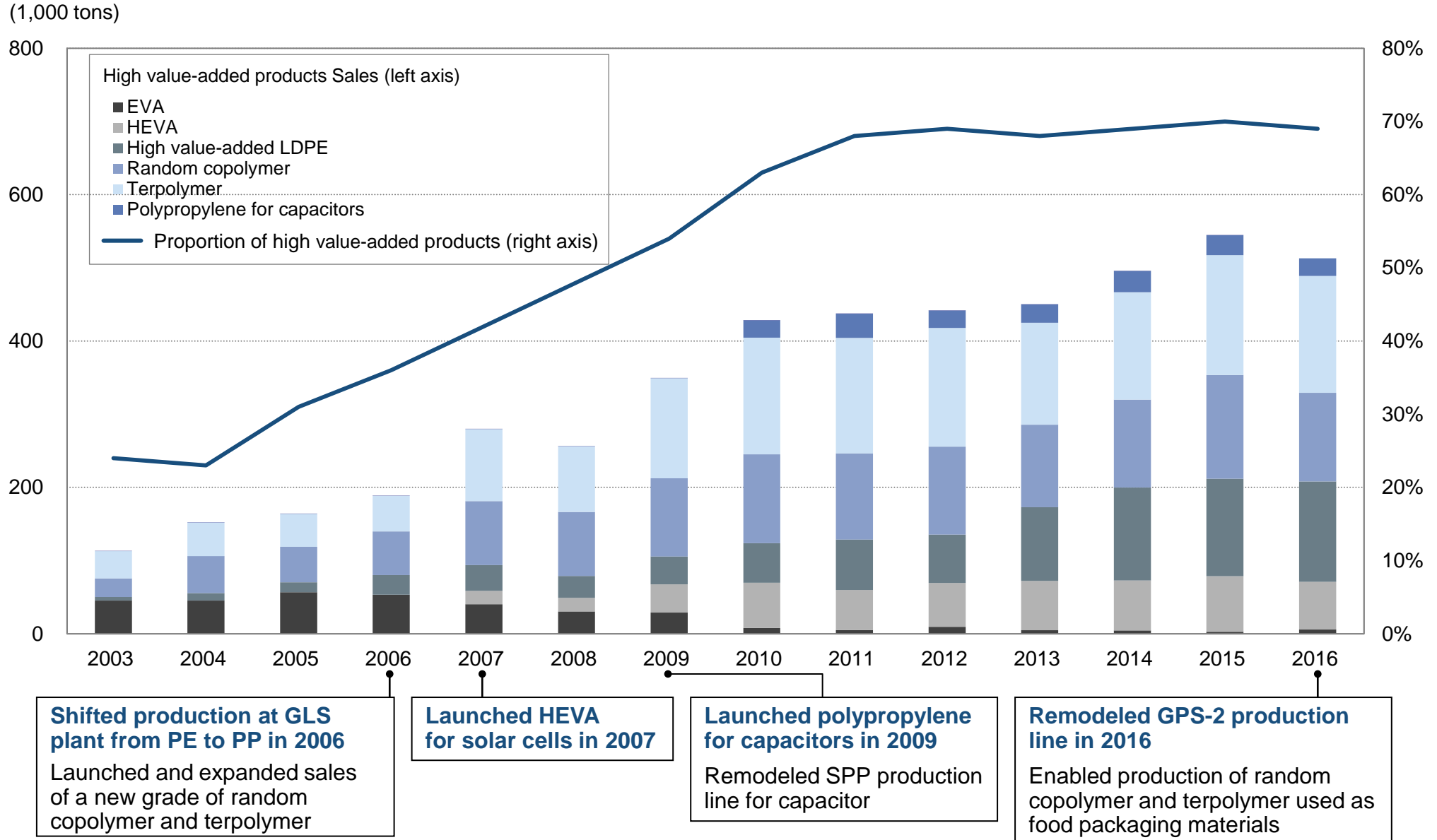

# Petrochemicals & Plastics: Petro Rabigh Complex

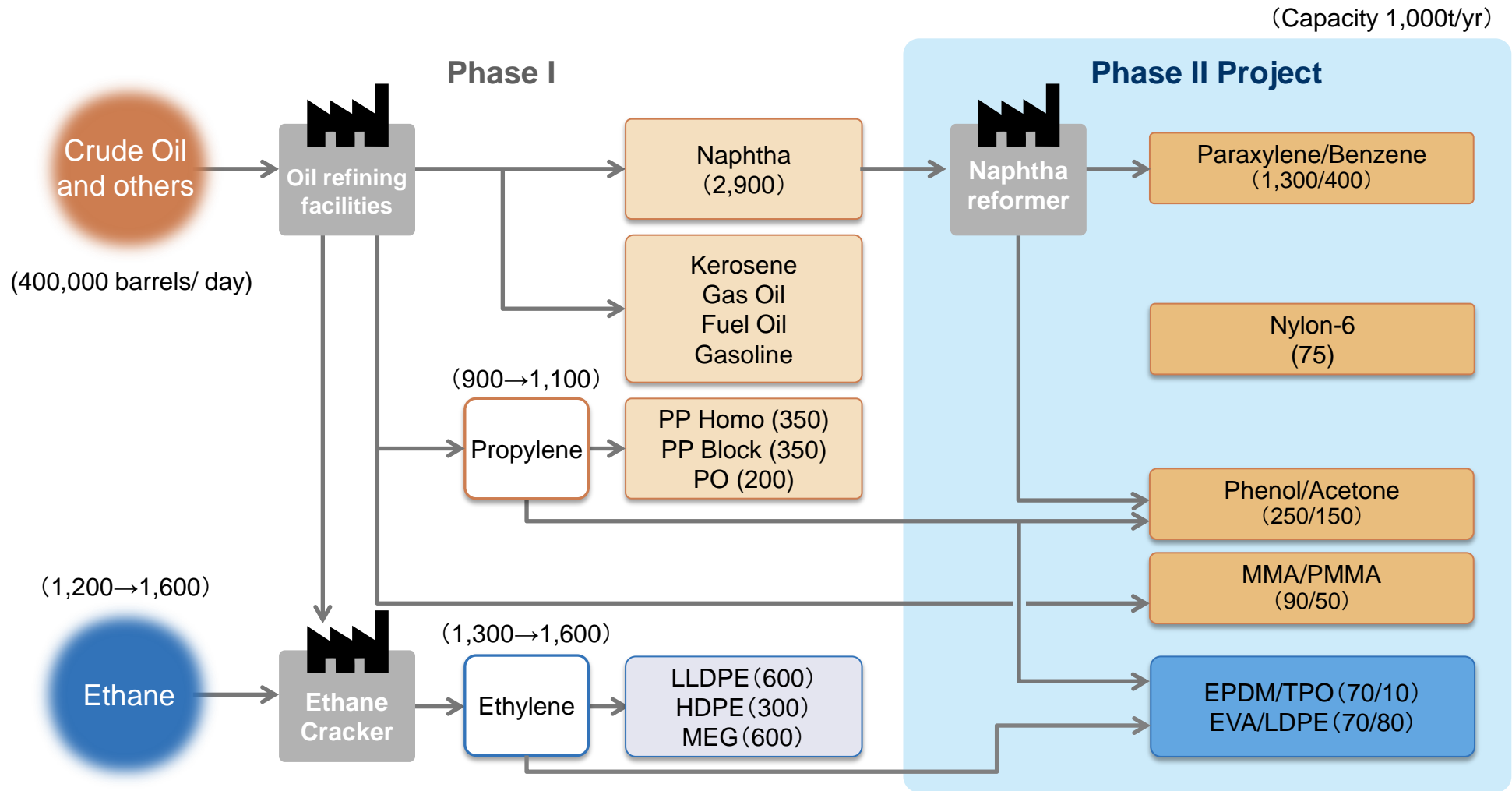

Investment in acrylic acid, SAP, and polyols is under consideration

## Progress in Achieving Goals Mainly in Core Businesses

- Core Business Trends and Business Strategy
- Results for 2016

# Results for FY2016: Life Sciences

	Health & Crop Sciences Sector	Pharmaceuticals Sector
<b>Business Expansion</b>		
<b>M&amp;A</b>	<ul style="list-style-type: none"> <li>● Acquired Indian agrochemicals company</li> </ul>	<ul style="list-style-type: none"> <li>● Acquired a Phase III product candidate for Parkinson's disease</li> <li>● Acquired a hematologic cancer</li> <li>● Licensed COPD treatments</li> </ul>
<b>Organic Growth (Production capacity expansion)</b>	<ul style="list-style-type: none"> <li>● Decided to expand methionine production capacity</li> </ul>	
<b>Organic Growth (Others)</b>	<ul style="list-style-type: none"> <li>● Decided to expand R&amp;D facilities and experimental field for agrochemicals</li> <li>● Collaboration with Monsanto in herbicide development</li> </ul>	<ul style="list-style-type: none"> <li>● Applied for U.S. FDA approval of COPD treatments</li> </ul>
<b>Business Restructuring</b>		<ul style="list-style-type: none"> <li>● Early retirement program (Sumitomo Dainippon Pharma)</li> </ul>

# Results for FY2016: Environment and Energy/ICT

	Energy & Functional Materials Sector	IT-related Chemicals Sector
<b>Business Expansion</b>		
<b>M&amp;A</b>	<ul style="list-style-type: none"> <li>Entered cathode materials business</li> </ul>	
<b>Organic Growth (Production capacity expansion)</b>	<ul style="list-style-type: none"> <li>Decided to expand separator production capacity</li> <li>Decided to expand for super engineering plastics production capacity</li> </ul>	<ul style="list-style-type: none"> <li>Expanded glass-based touchscreen panel production capacity</li> <li>Decided to expand film-based touchscreen panel production capacity</li> </ul>
<b>Organic Growth (Others)</b>	 <ul style="list-style-type: none"> <li>Established joint venture in S-SBR business</li> </ul>	<ul style="list-style-type: none"> <li>Advancing development of materials for flexible displays</li> <li>Advancing development of polymer OLEDs</li> </ul>
<b>Business Restructuring</b>		<ul style="list-style-type: none"> <li>Polarizing film</li> <li>Sapphire substrates</li> </ul>



# Results for FY2016: Bulk Chemicals

## Petrochemicals & Plastics Sector

### Business Expansion

#### M&A

- Made polycarbonate joint venture a wholly owned subsidiary

#### Organic Growth (Production capacity expansion)

- Proceeding with construction for Rabigh Phase II Project
- Expanded polypropylene compound production capacity

#### Organic Growth (Others)

- Accelerating the shift to high value-added products at TPC

### Business Restructuring

- Consolidation of film business



# Capital Expenditure and Investment Plan for FY2016-FY2018 (By Fiscal Year)

## Capital expenditure and investment plan for FY2016-FY2018 (decision-making basis)

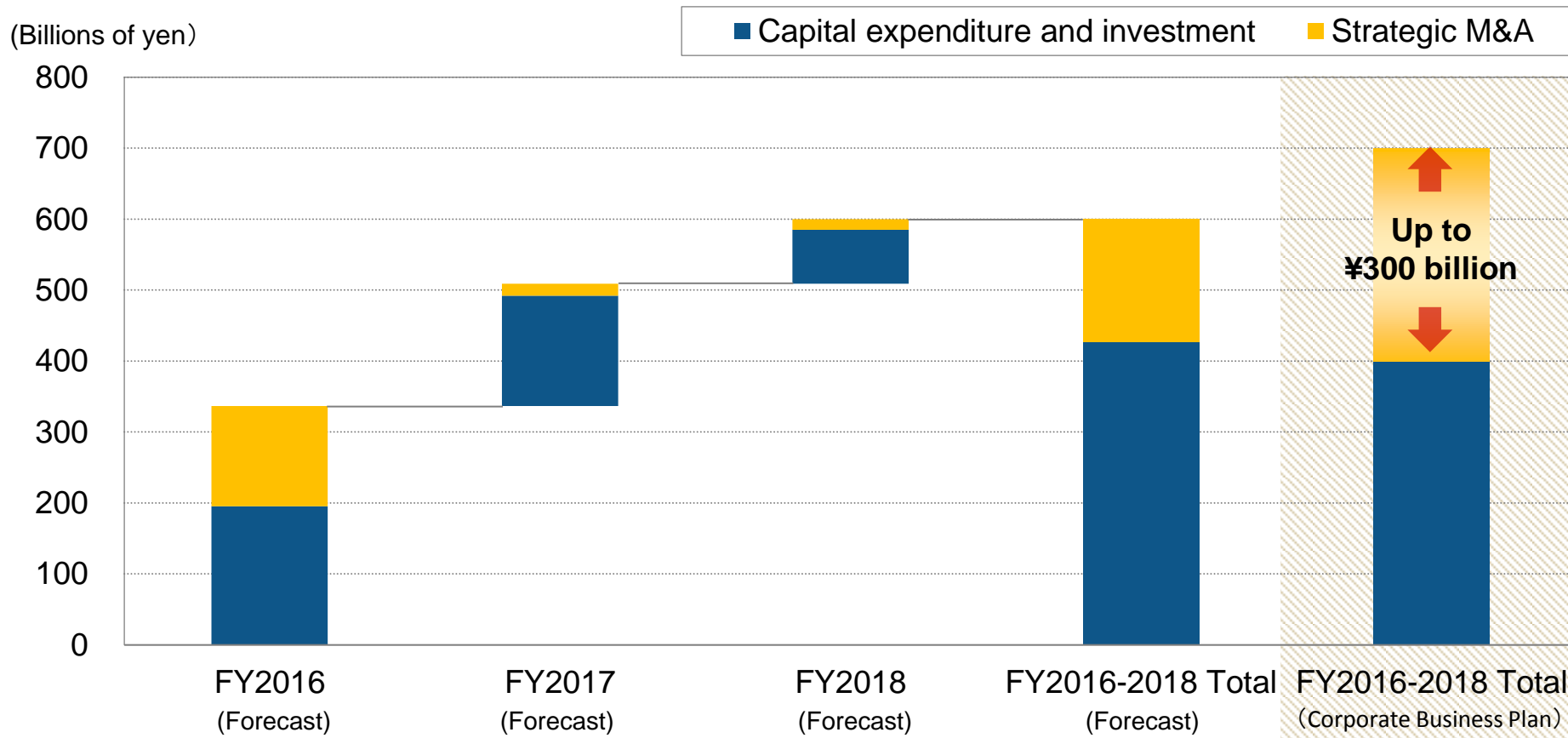

**More than half of investments for FY2016-FY2018 decided in FY2016**



**Accelerate our efforts to create new value**

# Capital Expenditure and Investment Plan for FY2016-FY2018 (By Sector)

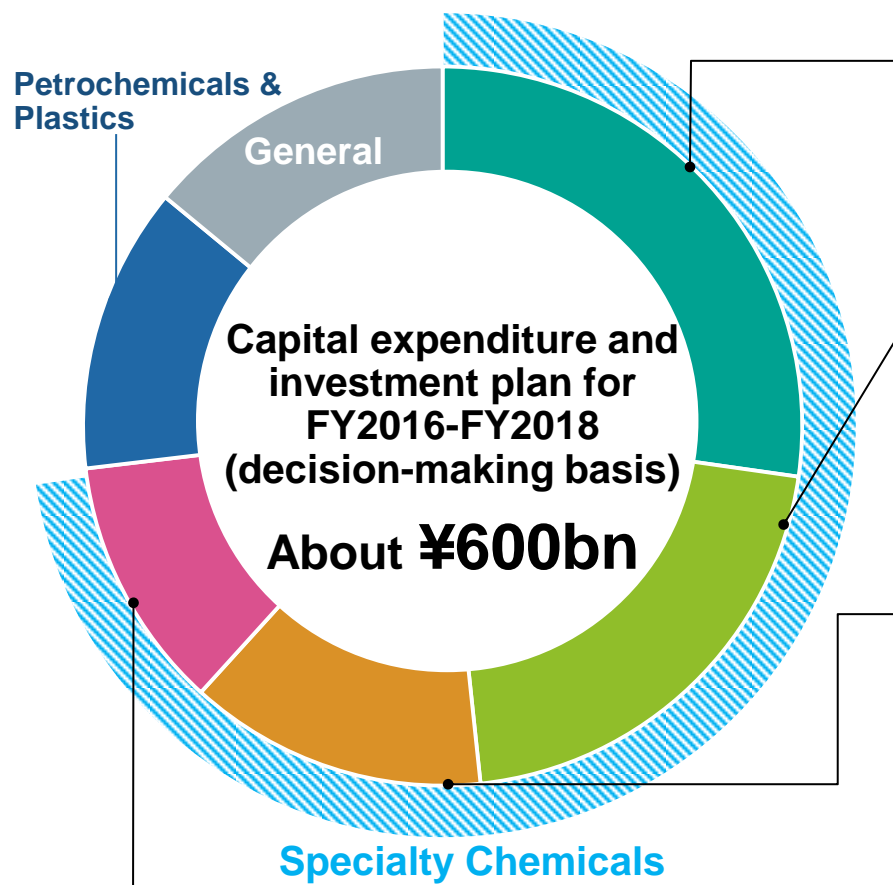

## Major Capital Expenditures and Investments



### Pharmaceuticals

- Acquired a Phase III product candidate for Parkinson's disease (about \$635 million)
- Acquired a leukemia treatment candidate (about \$780 million, including development and sales milestone payments)



### Health & Crop Sciences

- Increase methionine production capacity (about ¥50 billion)
- Acquired Indian agrochemicals company (about ¥13.9 billion)
- Expanded R&D facilities (about ¥10 billion)



### IT-related Chemicals

- Expanded film-based touchscreen panel production capacity (about ¥9 billion)
- Flexible display materials



### Energy & Functional Materials

- Expand separator production capacity (about ¥25 billion)
- Entered cathode materials business (about ¥7 billion)

# Initiatives toward Sustained Growth

- ❑ **Build Foundations for Sustained Growth**
- ❑ **ESG Initiatives**

# Initiatives toward Sustained Growth

- Build Foundations for Sustained Growth**
- ESG Initiatives

# What Sumitomo Chemical Strives To Be: Initiatives For Enhancing Enterprise Value

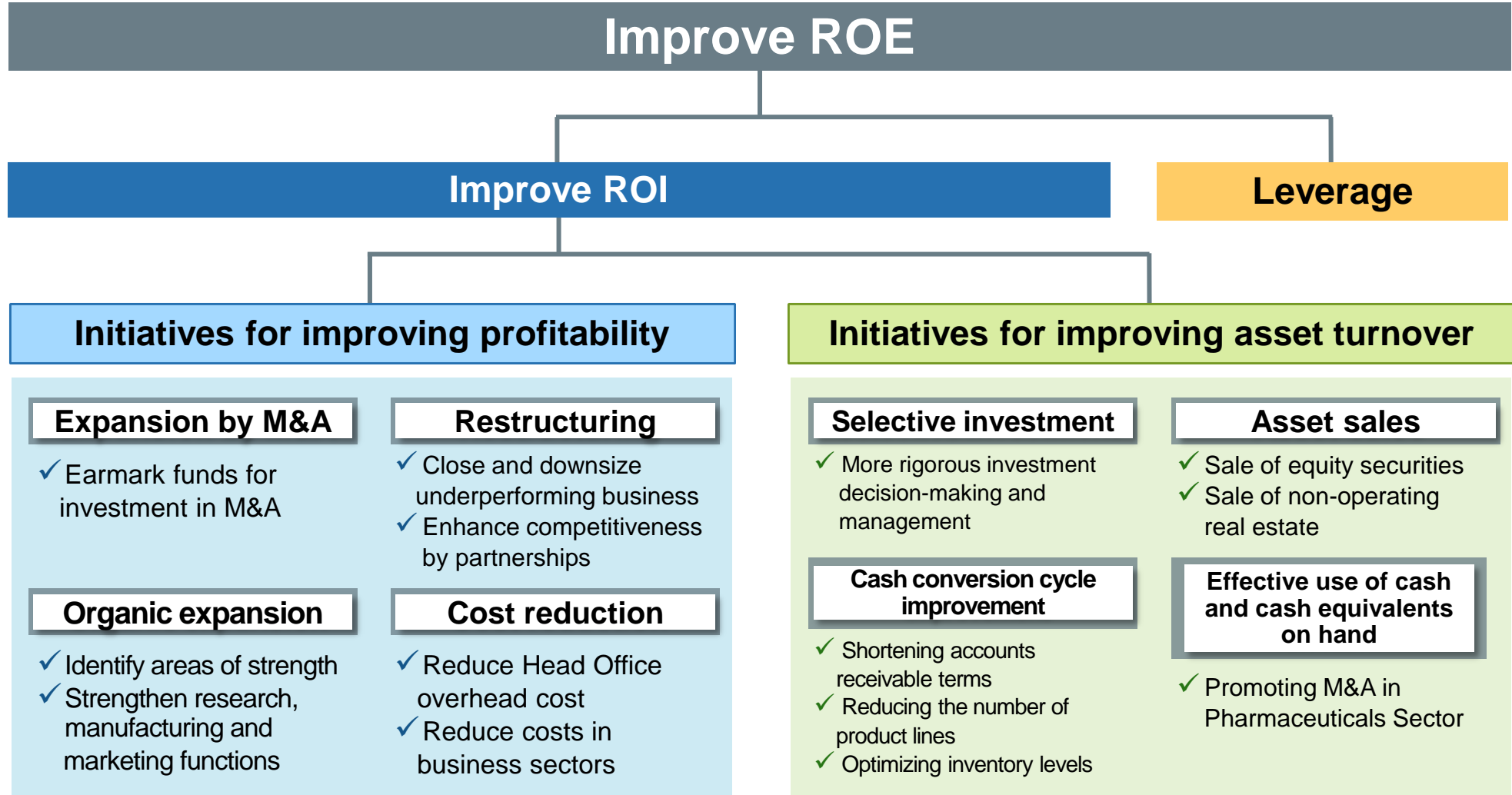

**Promote initiatives for enhancing enterprise value (ROI)**

# What Sumitomo Chemical Strives To Be: Further improve business portfolio

## Operating Income from Specialty Chemicals

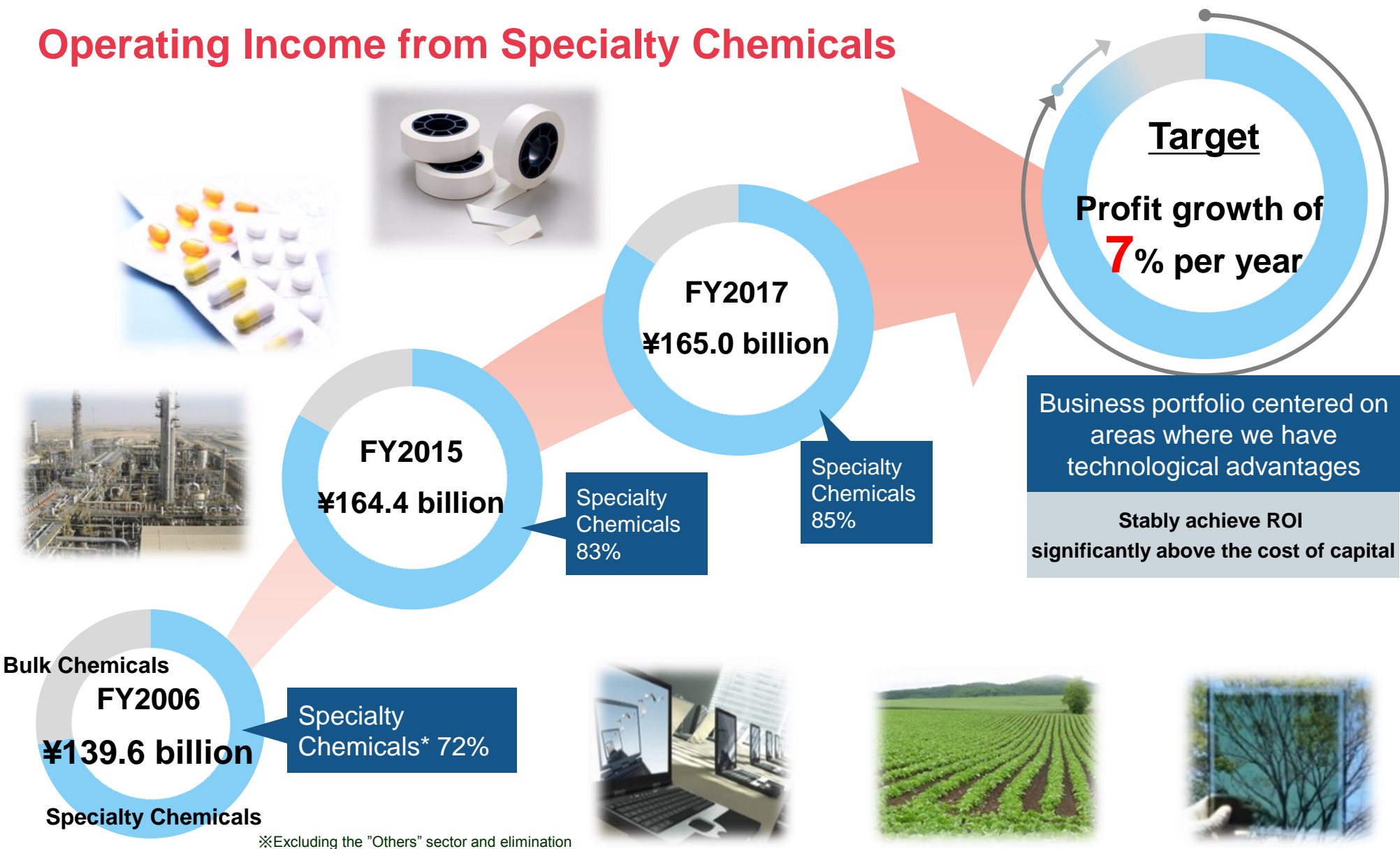

# Initiatives Maintaining Sustained Growth: Cash Flow Management

## Interest-Bearing Liabilities and Debt to Equity Ratio

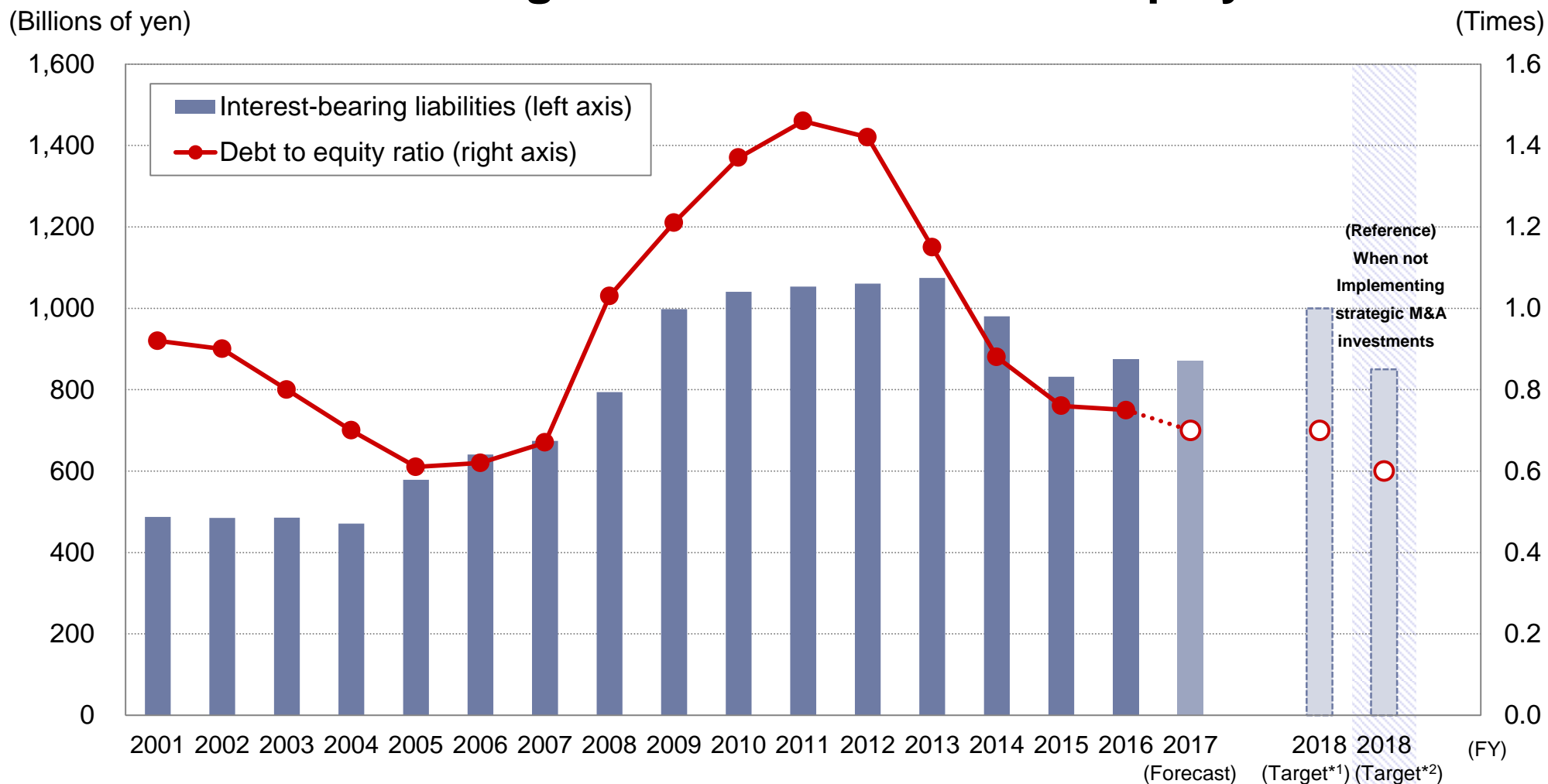

※1 Including investment in Rabigh Phase II Project; including the effects of investments in strategic M&A

※2 Including investment in Rabigh Phase II Project; not including the effects of investments in strategic M&A



Initiatives Maintaining Sustained Growth: New Business Development By Leveraging Core Technologies

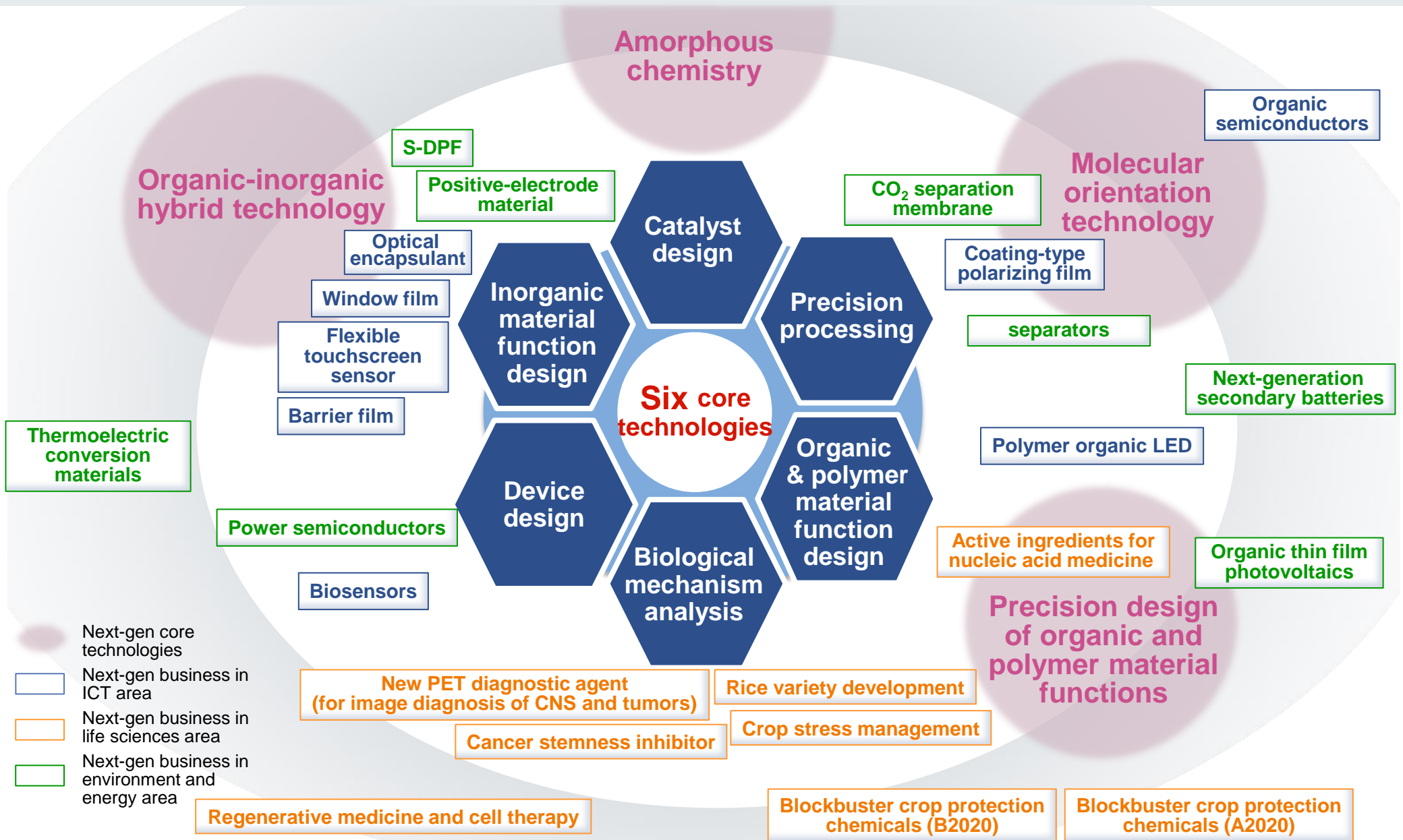

# What Sumitomo Chemical Strives To Be: Promote Open Innovation

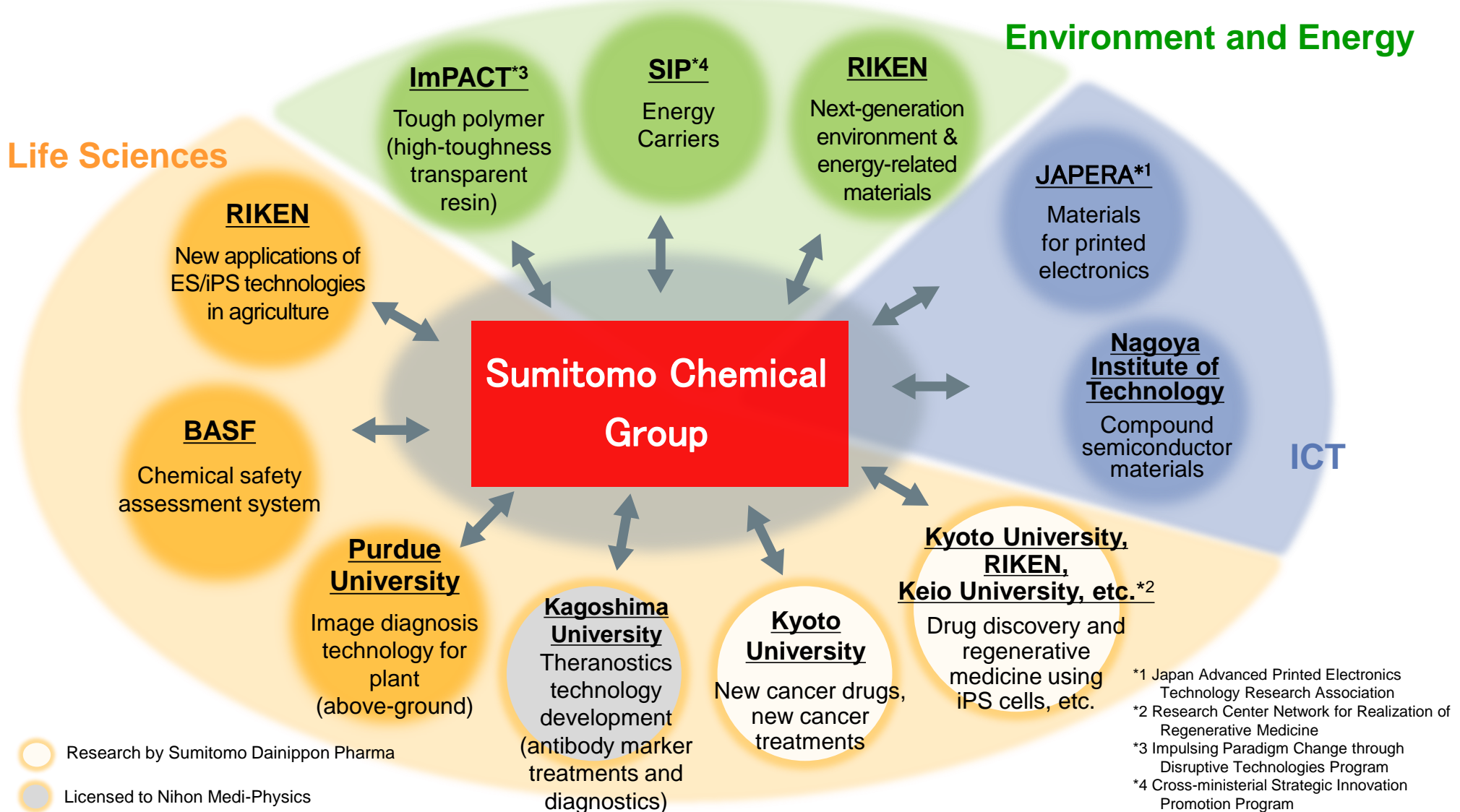

**Accelerate the development of next-generation businesses by leveraging both internal and external expertise**

# Initiatives Maintaining Sustained Growth: IoT Project

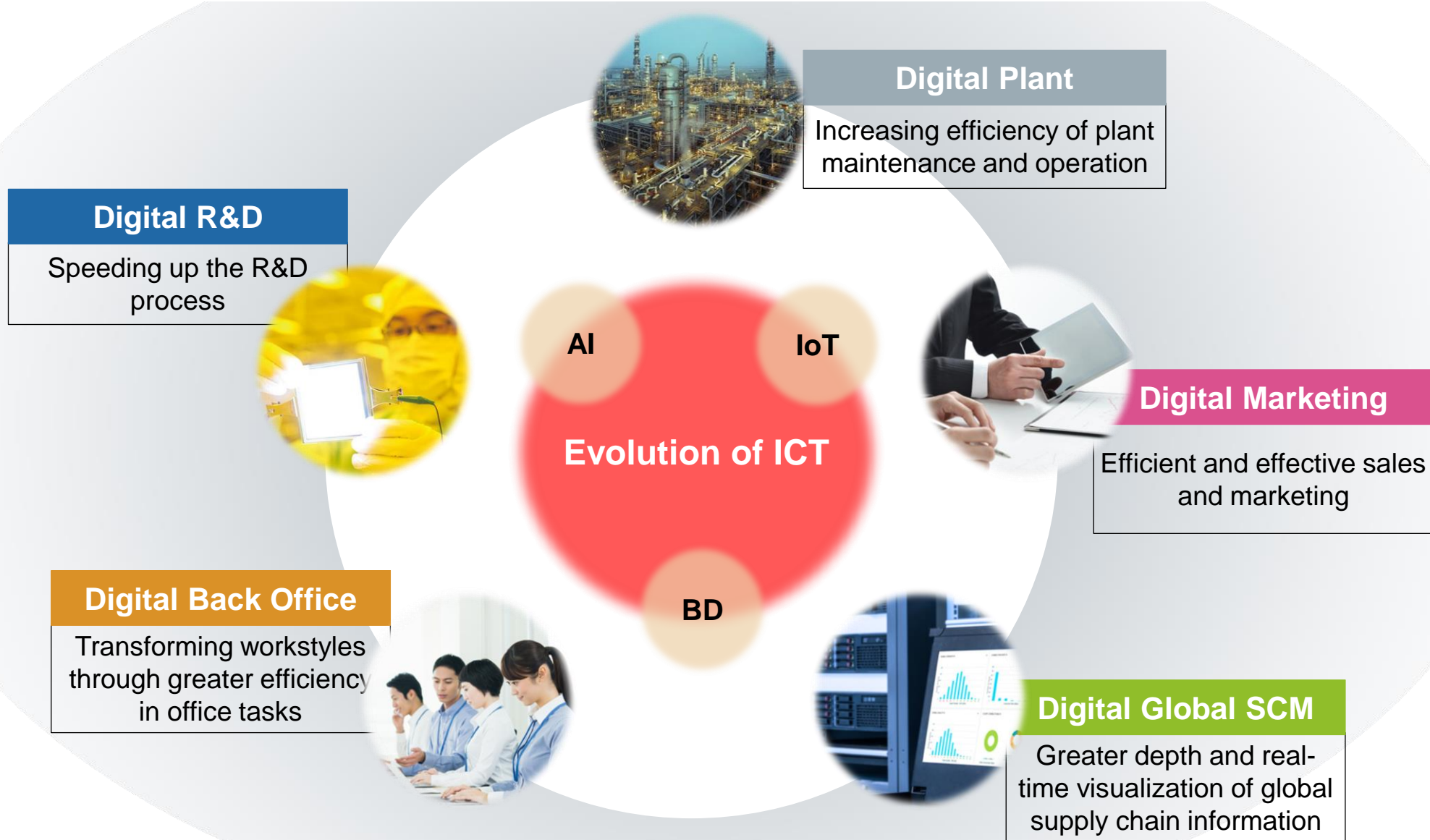

# Initiatives toward Sustained Growth

- Build Foundations for Sustained Growth
- **ESG Initiatives**

# Initiatives Maintaining Sustained Growth: Corporate Governance

## Change in the Functions of Board of Directors

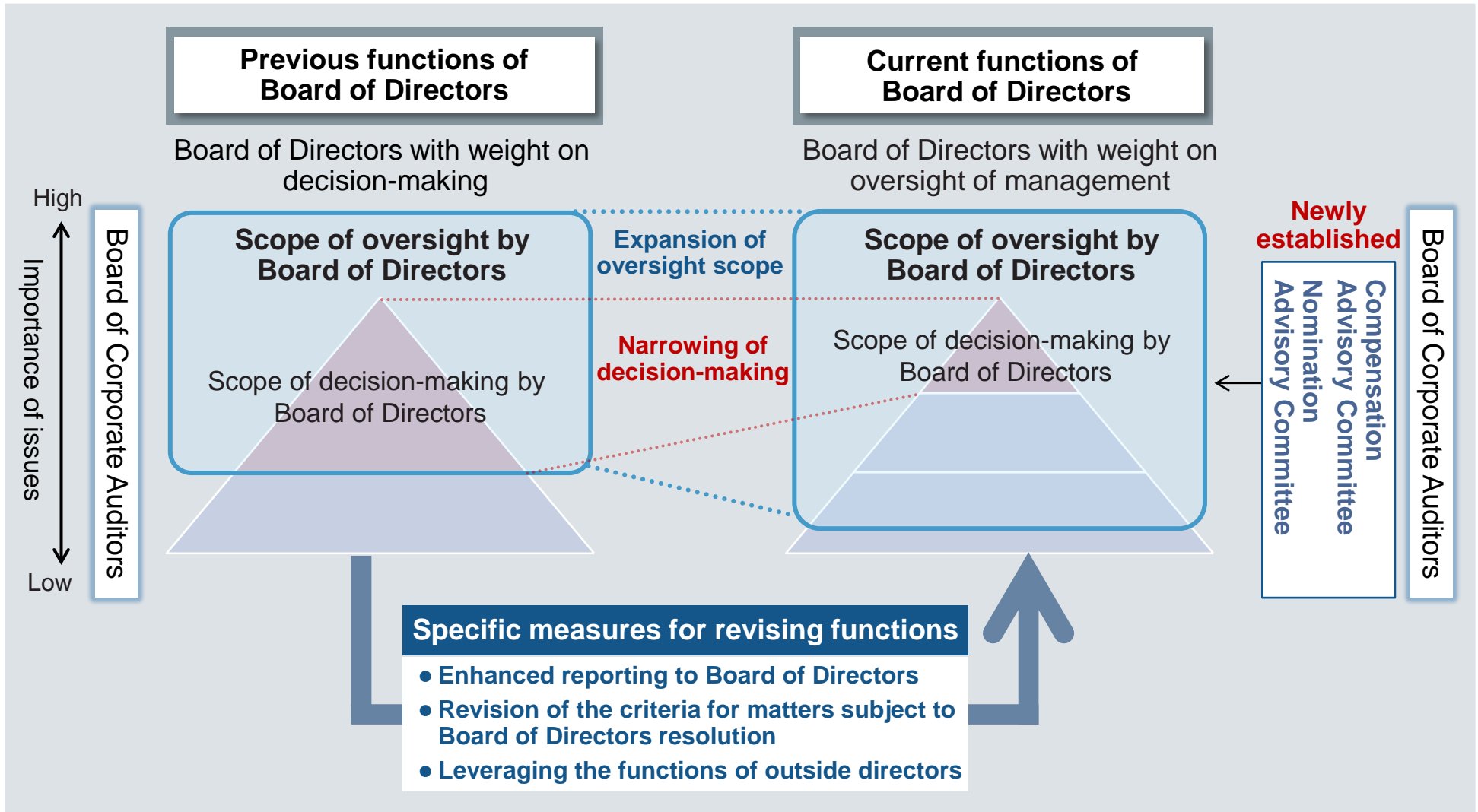

# Initiatives Maintaining Sustained Growth: Governance

## PDCA cycle for further improving the effectiveness of the Board of Directors

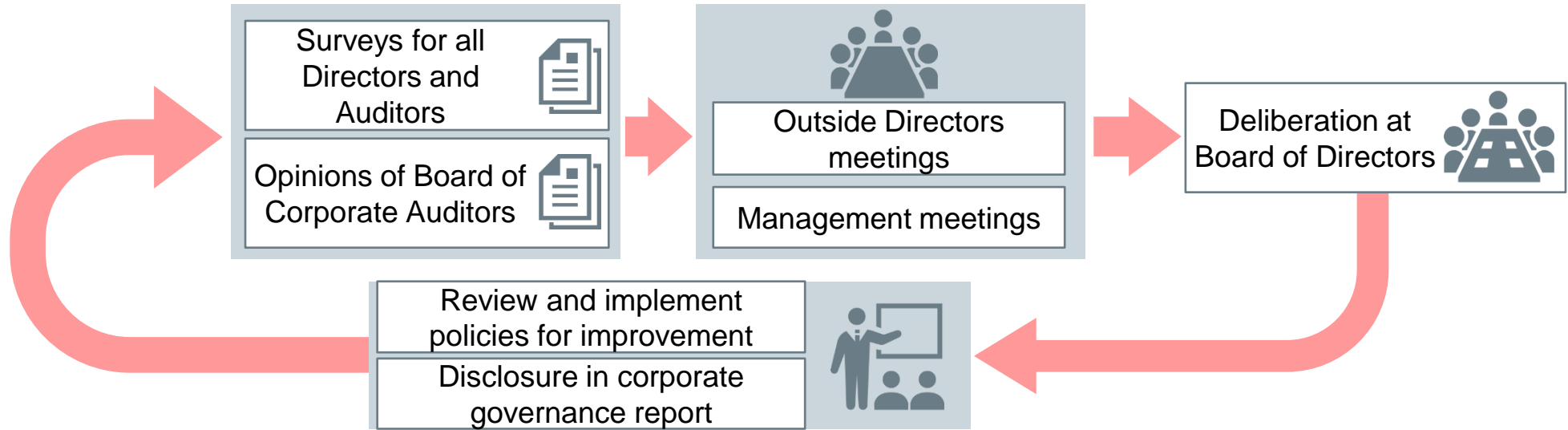

### Examples of Policies for Improvement

Strengthened reporting on task execution status to outside directors

- ✓ Rotation reports and spot reports on important cases

Shared discussion with outside directors in internal meetings

- ✓ Disclosure of the content discussed in management meetings

Factory tours for outside directors

- ✓ Twice-yearly inspections of plants both inside and outside Japan

Rotation report: A comprehensive and systematic report at a set time for each field; Spot reports on important cases: Advance reports on potential large-scale investments etc.

Outside directors visiting Sumitomo Chemical Singapore



# Initiatives Maintaining Sustained Growth: CSR Activities Based on SDGs

## Major themes for Sumitomo Chemical Group's CSR Activities for FY2017

Each of us will always be aware of how we contribute to society through our work

1. Each of us will play an active role in economic, social and responsible care activities
2. We will deepen our understanding of SDGs, ask ourselves what to do to further contribute to the future of society and take action while enlightening one another.
3. We will effectively communicate the significance of the ties of business and society, both internally and externally



## Each Sector's 'SDGs'

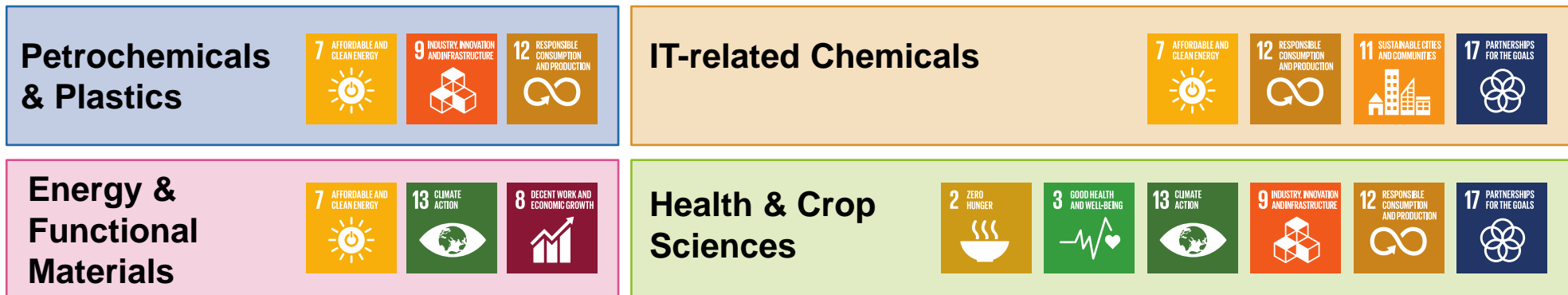

# Initiatives Maintaining Sustained Growth: Sumika Sustainable Solutions

## Sales of SSS-Certified Products and Technology

(Billions of yen)

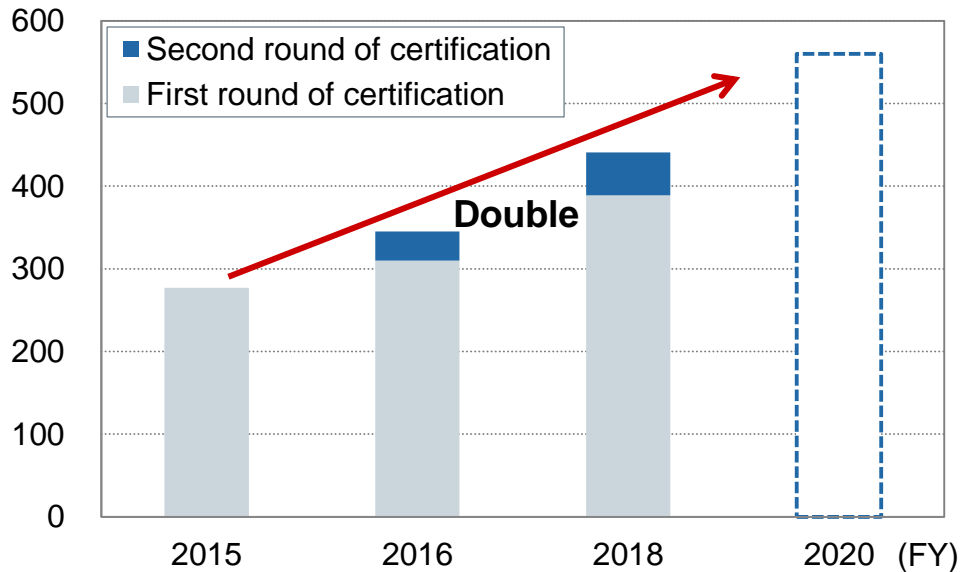

(Reference)

Certification Committee convened in May 2017

Certified 13 additional products and technologies  
(In total, 34 products and technologies have been certified)

## SSS-Certified Products and Technologies

1 Contribution to promoting the use of EVs

- Lithium-ion secondary battery separator PERVIO®



2 Contribution to fuel efficiency improvement by reducing the weight of aircraft

- Polyethersulfone SUMIKAEXCEL®



3 Significant energy saving in CO<sub>2</sub> separation in hydrogen production process

- CO<sub>2</sub> separation membrane

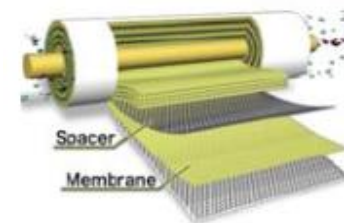

4 Reduced GHG emissions by reducing the nitrogen content in livestock waste

- Feed additive methionine SUMIMET®



Provide solutions to build a sustainable society → Address global challenges such as climate change



# Conclusion

# Sumitomo Chemical's Value Creation

## Improve Growth Rate

Concentrate management resources on the three growth areas and cross-over areas

Environment  
and  
Energy

Life  
Sciences

ICT

## Improve ROI

Improve  
profit margin

Improve  
asset  
turnover rate

## Continuation of the ESG initiatives

### Environment

Contribute to sustainable development of society through business

### Society

Build good relationships with stakeholders

### Governance

Improve the effectiveness of governance

**Towards achieving continuous value creation**

# What Sumitomo Chemical Strives To Be: Ten Years Ahead

## Trend of Ordinary Income

(Billions of yen)

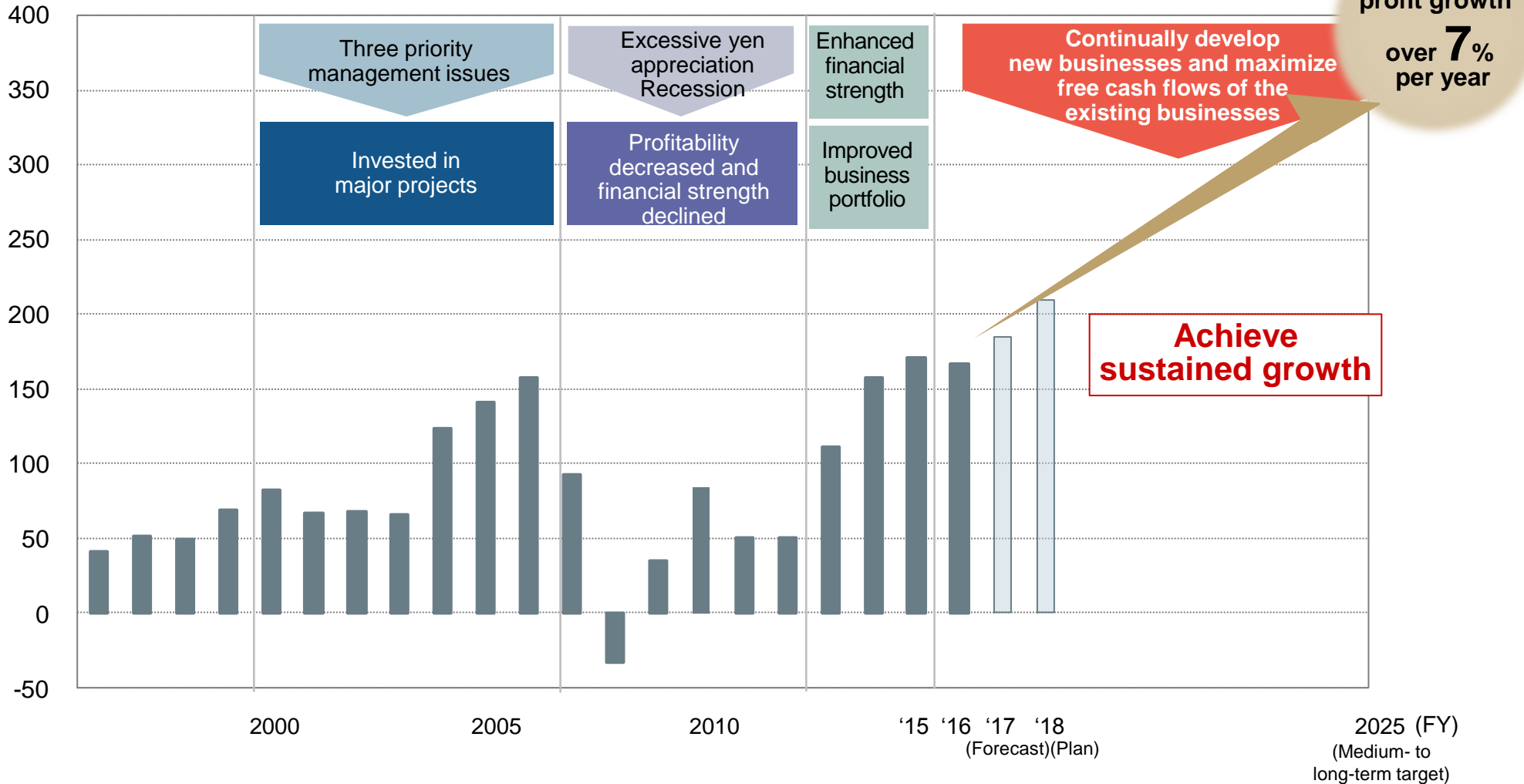

# Creative Hybrid Chemistry



# (Reference) Topics

# Contents

Create New Value

	Entire Company	71-73
	Health & Crop Sciences Sector	74-78
	Pharmaceuticals Sector	79-82
	Energy & Functional Materials Sector	83-85
	IT-related Chemicals Sector	86-89
	Petrochemicals & Plastics Sector	90
	ESG Initiatives	91-92



# Sumitomo Chemical's DNA

## Sumitomo Values

The Sumitomo Family's "Business Principles" state that as we conduct business, we must value trust and integrity, and thereby strive to thrive, and that we must closely watch the changing of the times, carefully weighing opportunities and risks, never chasing short-term gains, in good times and bad.

At Sumitomo Chemical we adhere to the principle that our business must not only benefit our own interests but also society at large.

## The origin of Sumitomo Chemical

Sumitomo Chemical's history dates back to 1913. The company got its start by producing fertilizer from harmful gas emitted in copper smelting operations. The business helped mitigate the environmental problem caused by the emissions, while also contributing to increasing agricultural crop production.

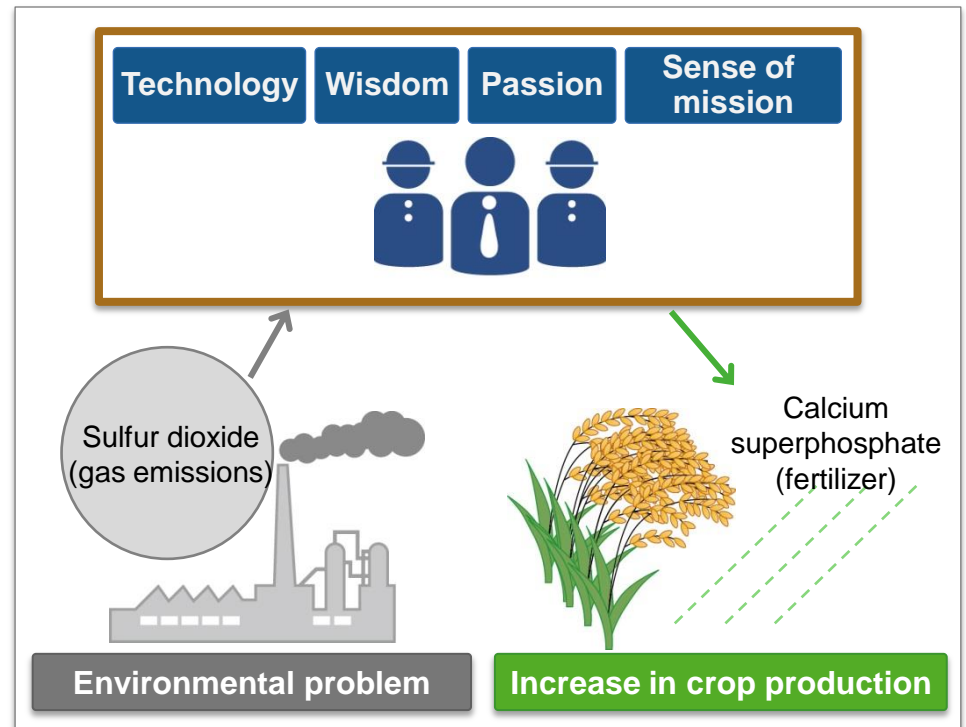

# Performance Targets under the Corporate Business Plan

(Billions of yen)

	FY2015	FY2016	FY2017 Forecast	FY2018 Target
Net Sales	2,101.8	1,954.3	2,190.0	2,540.0
Operating Income	164.4	134.3	165.0	200.0
(Equity in Earnings of Affiliates)	20.2	41.2	35.0	29.0
Ordinary Income	171.2	166.6	185.0	210.0
Net Income	81.5	85.5	100.0	110.0
Interest-bearing Liabilities	831.5	875.3	870.0	1,000.0*1
Naphtha Price	¥42,800/kl	¥34,700/kl	¥37,000/kl	¥45,000/kl
Exchange Rate	¥120.15/\$	¥108.34/\$	¥110.00/\$	¥120.00/\$

\*1: Including the effects of investments in strategic M&amp;A



# What Sumitomo Chemical Strives To Be: Ten Years Ahead

	FY2006	FY2015	FY2017 (Forecast)	FY2018 (Plan)	Targets
ROI	8%	6%	7%	7%	Over 7%
ROE	12%	10%	12%	12%	Over 10%
D/E ratio	0.6times	0.8times	0.7times	0.6~0.7* <sup>1</sup> times	0.7 times
Dividend payout ratio	21%	28%	23%	Undecided	Approx. 30%

**Consistently  
achieve these  
targets**

\*1: Including the effects of investments in strategic M&A

# Health & Crop Sciences Sector: Biorationals

## Microbial pesticides

Core products	Major applications
DiPel®	Microbial pesticide that can be used for a wide variety of crops
XenTari®	Same as above

### Our strengths

- Superior BT (*Bacillus thuringiensis*) strains
- Outstanding production (fermentation) expertise



**Stable supply of highly effective microbial pesticides**

## Plant growth regulators

Core products	Major applications
ProGibb®	Controls growth and size of crops
Promalin®	Thins out fruits, controls size
ReTain®	Regulates harvest time for fruits, prevents fruit drop
ProTone®	Controls coloring of fruits, delays germination

### Our strengths

- Pioneer of the plant growth regulator business
- Selling a wide range of plant growth regulators in more than 90 countries
- Capabilities to develop new markets by creating new solutions



**Support for the cultivation of high quality crops**

## Microbial agricultural materials

Core products	Major applications
Mycorrhizal fungi	Promotes efficient absorption of water and nutrients in soil

### Our strengths

- Technology for mass production of mycorrhizal fungi
- Expertise and proven track record for applying mycorrhizal fungi for a wide range of crops



**Stable supply of high quality mycorrhizal fungi**

# Health & Crop Sciences Sector: Development of Rice Business

## Rice business objectives

- Solve the problems facing the agricultural sector in Japan
- Consolidate our Total Solution Provider business
- Develop high-yield, tasty rice varieties

**Help strengthen Japan's agricultural sector**

## Development of new varieties

High-speed breeding technology by using DNA markers

4 varieties registered and  
1 variety applied for registration

To develop more varieties to expand the rice business nationwide and to meet various customer needs for rice properties



Current: Focusing on sales to large-scale rice businesses

**Future: Expand sales to a wider range of customers, including consumers and sake manufacturers, and also increase export sales**

## Three varieties currently cultivated

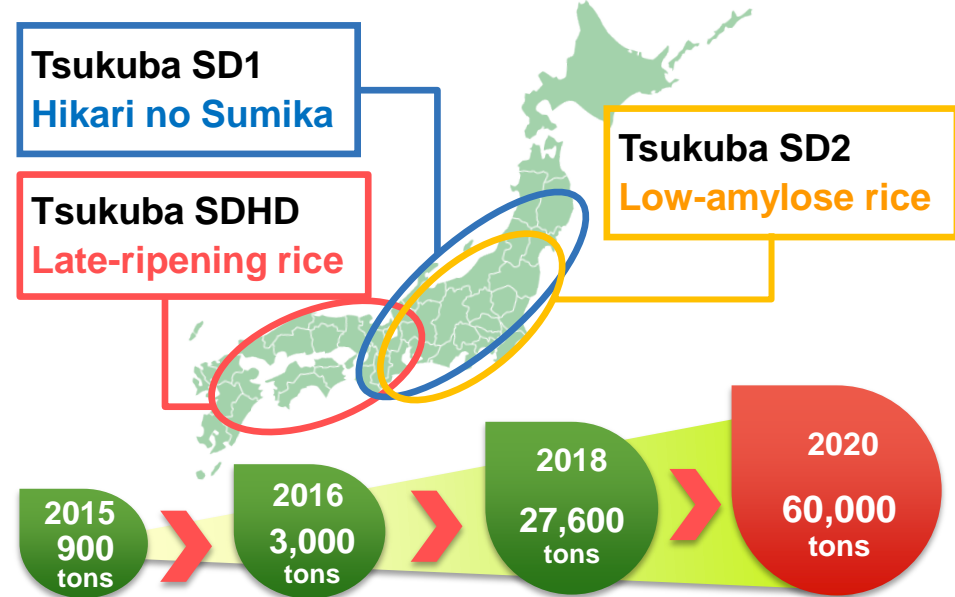

## Customers

Product name	Prospective customers
<b>SD1</b> (Hikari no Sumika)	Major restaurant chains (franchises) Major noodle-shop chains Major delicatessen companies Major <i>bento</i> (boxed meals) suppliers Major supermarkets (prepared food)
<b>SD2</b> (low-amylose)	Major convenience store chains

# Health & Crop Sciences Sector: Enhance Global Footprint

## Excel Crop Care Limited

### 1 Acquisition of Excel Crop Care, Indian Agrochemicals Company

**Business:** Development, manufacture and sale of agrochemicals

**Sales:** 9.5 billion rupees (about 15.5 billion yen) in FY2016

**Headquarters:** Mumbai, India

### 2 Outline of the stock acquisition

**Acquired stake:** 65%

**Acquisition value:** 9 billion rupees (about 13.9 billion yen)

### Aim of acquisition

- Expand sales channels in India
- Leverage Excel Crop Care's brand

The world agrochemicals market in FY2015

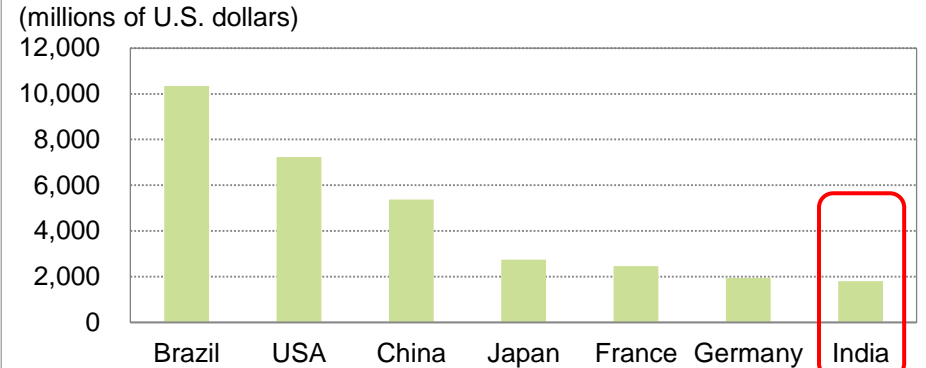

Source: Phillips McDougall

Share in the Indian agrochemicals market in FY2014

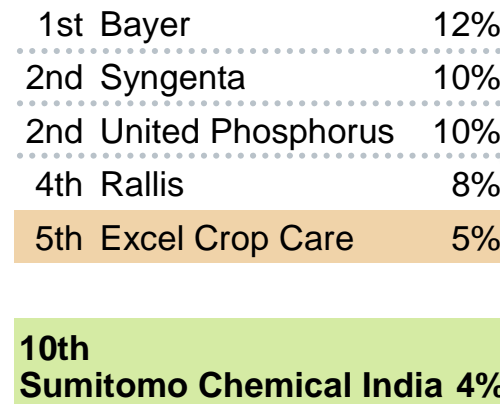

Excel Crop Care and Sumitomo Chemical India combine to become the fourth largest

Aiming to become the market leader in India

Source: Phillips McDougall

**Increase our presence in the growing Indian market and enhance our global footprint**

# Health & Crop Sciences Sector: Accelerating the Search for Agrichemicals and Taking on the Challenge of New Agrichemicals Businesses

## Agrichemicals until Now

- Pesticides
- Fungicides
- Herbicides



Target: **Harmful Life**  
 Kill organisms harmful to crops

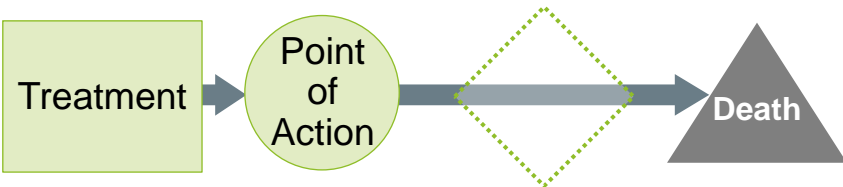

## New Field of Agrichemicals

- Increased yield
- Enhanced tolerance
- Plant stimulation



Target: **Crops**  
 Controlling crops to **increase** yield

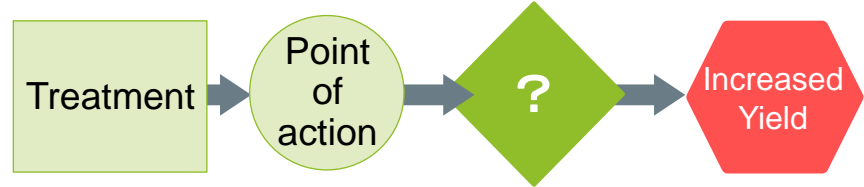

**Build a technology platform that can respond to new waves**

# Health & Crop Sciences Sector: Increase Methionine Production Capacity

## Competitive advantage in methionine business



## Production capacity expansion

**Product:** DL-methionine

**Production capacity:**  
100,000 tons

**Location:** Ehime Works

**Start of operation:**  
Mid 2018

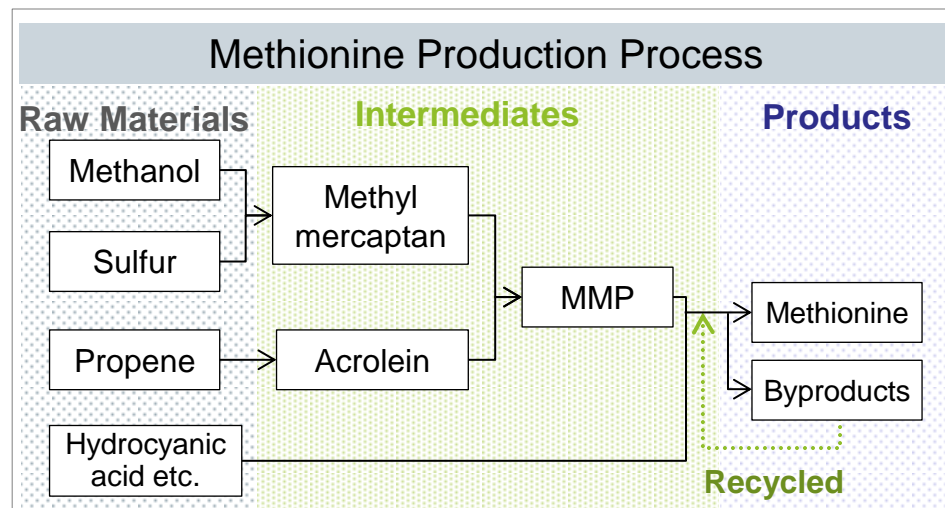
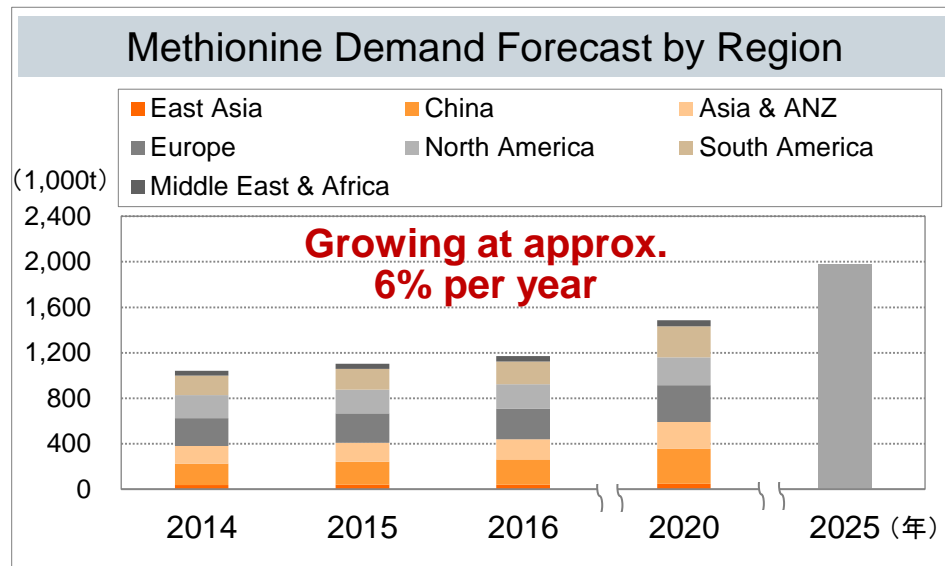

**Reinforce our position as Asia's leading methionine player**

# Pharmaceuticals Sector: Planned Future Launches

## Treatments Acquired Since May 2016

### Parkinson's Disease Treatment

- Acquired Cynapsus Therapeutics in October 2016
- APL-130277 (Phase III in U.S.)

### COPD Treatments

- License agreement signed with Novartis in December 2016
- UTIBRON, SEEBRI, ARCAPTA (Approved in U.S.)

### Hematologic Cancer Treatment

- Acquired Tolero Pharmaceuticals in January 2017
- Alvocidib (Phase II in U.S.)

## Other Planned Launches

### Oncology area

- Cancer stem-cell inhibitor Napabucasin\* (Japan and U.S.)
- Cancer stem-cell inhibitor Amcasertib\* (Japan and U.S.)
- Cancer peptide vaccine DSP-7888 (Japan and U.S.)

\* Introduced by Boston Biomedical, Inc

### Other areas

- COPD treatment SUN-101 (U.S.)
- ADHD/BED treatment Dasotraline (U.S.)
- Chronic stroke treatment SB623 (U.S.)
- Atypical antipsychotic Lurasidone (Japan)
- NASH treatment DSP-1747 (Japan)

# Pharmaceuticals: Portfolio for COPD

## Chronic Obstructive Pulmonary Disease (COPD)

The 3rd leading cause of death in U.S.  
\*

>120k deaths per year in the U.S.  
\*

~15.7m adults affected in the U.S.  
\*

Increasing prevalence with aging population

\* MMWR: Morbidity and Mortality Weekly Report. Employment and Activity Limitations Among Adults with Chronic Obstructive Pulmonary Disease.

### Disease Severity

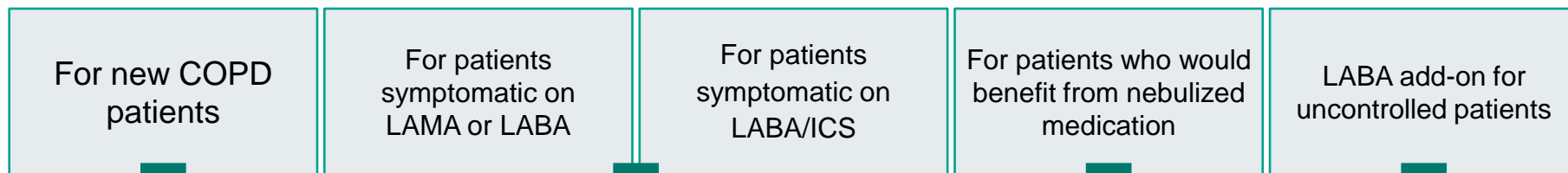



or



SUN-101 / eFlow<sup>®</sup>



NEBULIZE WITH  
**Brovana<sup>®</sup> 15**  
INCS  
*(arformoterol tartrate) Inhalation Solution*

Full trade names are: Seebri™ Neohaler®, Utibron™ Neohaler® and Arcapta® Neohaler®  
 ARCAPTA and  are registered trademarks of Novartis AG, used under license  
 SEEBRI and  are trademarks of Novartis AG, used under license  
 UTIBRON and  are trademarks of Novartis AG, used under license

eFlow<sup>®</sup> device technology licensed from PARI Pharma GmbH



# Pharmaceuticals: Major Products under Development

## COPD Treatment (NDA filed)

### Indication

Chronic obstructive pulmonary disease (COPD)

### Features

1. Administered by nebulizer\*
2. Short delivery times (2-3 min)

### Development and Launch Schedule

Current: NDA filed (US)  
During FY2017:  
Planned launch (US)



SUN-101/eFlow®  
electronic nebulizer

\* Nebulizer: Device for delivering drugs through the lungs

**Expected peak sales about 50.0 billion yen**

eFlow® device technology  
licensed from PARI Pharma GmbH

## Cancer Stem Cell Inhibitor

### Indication

Cancer

### Features

First-in-class molecularly targeted treatment

### Development and Launch Schedule

Inhibits cellular proliferation and induces apoptosis for cancer cells and cancer stem cells

### Napabucasin

Current: In phase III clinical trials\*<sup>1</sup>  
FY2018: Submission planned\*<sup>2</sup>  
FY2019: Planned launch\*<sup>2</sup>

### Amcasertib

Current: In phase II clinical trials (U.S. and elsewhere)  
FY2020-22: Submission and planned launch for U.S. and elsewhere

\*<sup>1</sup> Including gastric and gastro-esophageal junction cancers, colorectal cancer, pancreatic cancer (U.S. and elsewhere)

\*<sup>2</sup> Gastric and gastro-esophageal junction cancers (U.S. and elsewhere)

**Expected peak sales about 100 billion yen**

**Making progress in new product development and in-licensing for post-LATUDA period**

# Pharmaceuticals Sector: Regenerative Medicine and Cell Therapy

## Short History of the Development of the Regenerative Medicine and Cell Therapy Fields

- 1990 Joint research with Harvard University on neuron regeneration

---

- 2001 Joint research with Keio University Professor Hideyuki Okano on spinal cord injuries

---

- 2001-05 Joint research with Nara Institute of Science and Technology Professor Shinya Yamanaka

---

- 2006 Joint research with RIKEN on ocular development (Sumitomo Chemical)

---

- 2010 Licensed SB623 (treatment for chronic stroke)

---

- 2013 Collaboration with Healios to commercialize regenerative medicine  
  
Started research under the Research Center Network for Realization of Regenerative Medicine program(spinal cord injury, Parkinson's disease)

---

- 2015 Acquired a stock of iPS cells for regenerative medicine from Kyoto University's Center for iPS Cell Research and Application (CiRA)

**Engaged in research leading to the development of regenerative medicine and cell therapy for 25 years**

## Collaboration Network for the Development of Regenerative Medicine and Cell Therapy

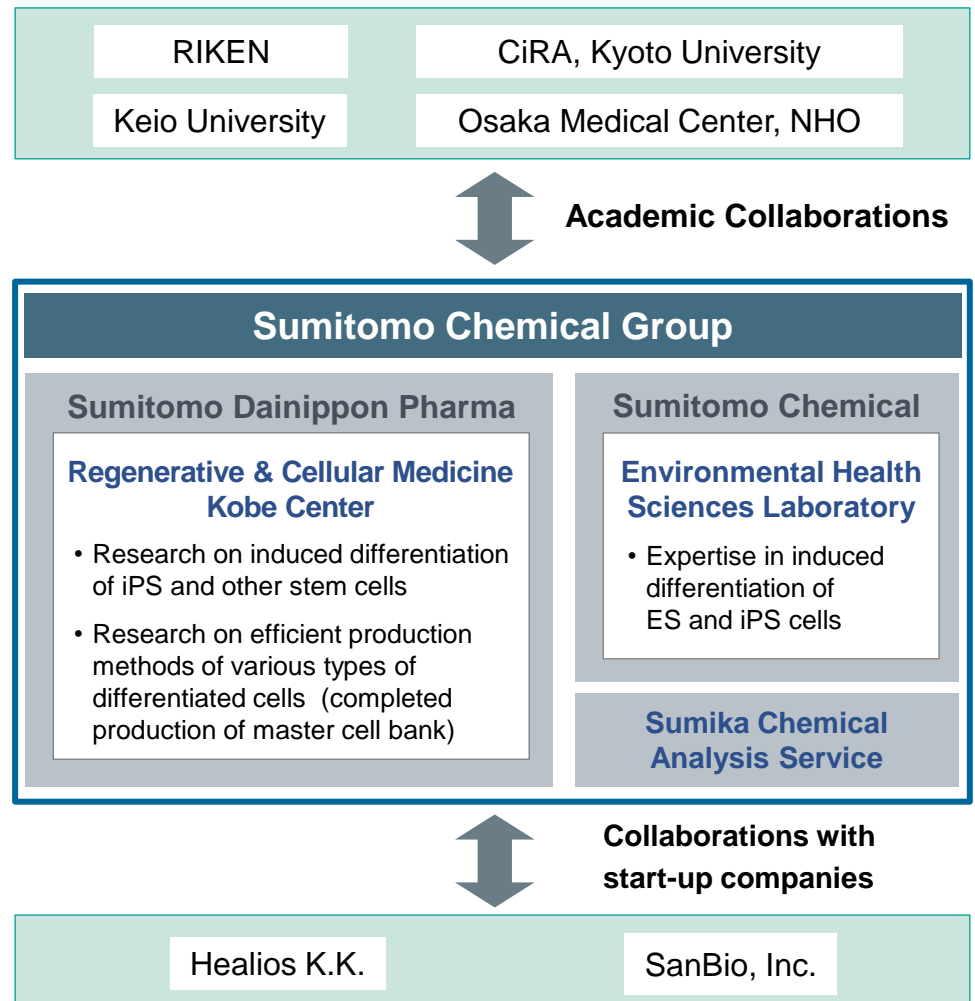

# Energy & Functional Materials Sector: Investment into Cathode Materials Business

## Profile of Tanaka Chemical Corporation

**Business:** Manufacture and sale of cathode materials and catalyst raw materials

**Net sales:** Approx. ¥13.3 billion in FY2016

## Became Sumitomo Chemical's subsidiary through private share placement

**Shares acquired:**

10.5 million  
(subscription value: Approx. ¥6.6 billion)

**Shares owned:**

12.7 million (investment ratio of 50.1%)

## Aim of acquisition

Accelerate development and launch of highly functional cathode materials for automotive batteries by leveraging the two companies' strengths.

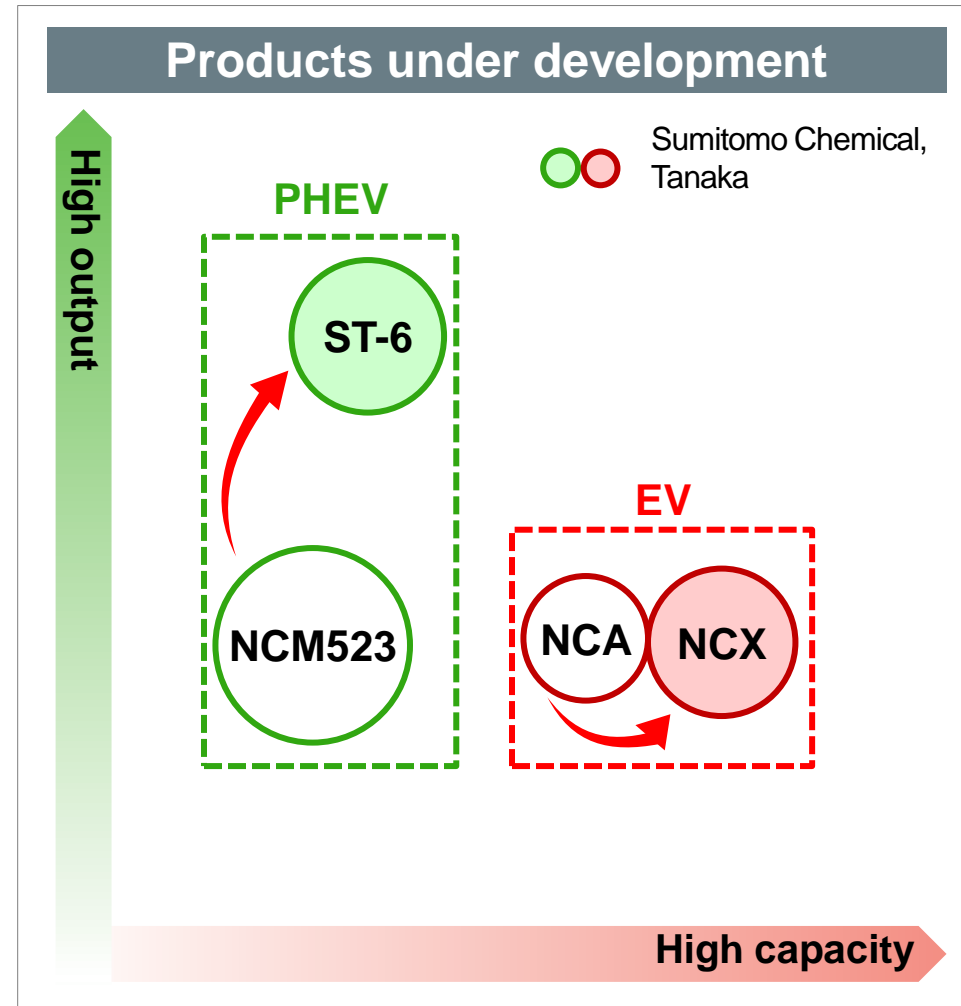

**Stepped up the investment in cathode materials business, aiming to have our products adopted for automotive batteries as soon as possible**

# Energy & Functional Materials Sector: CO<sub>2</sub> Separation Membrane

The CO<sub>2</sub> selective membrane system, installed upstream of CO<sub>2</sub> chemical absorption plants, removes approx. 50% of the CO<sub>2</sub> contained in the source gas, **reducing the steam cost** incurred in the absorption plant

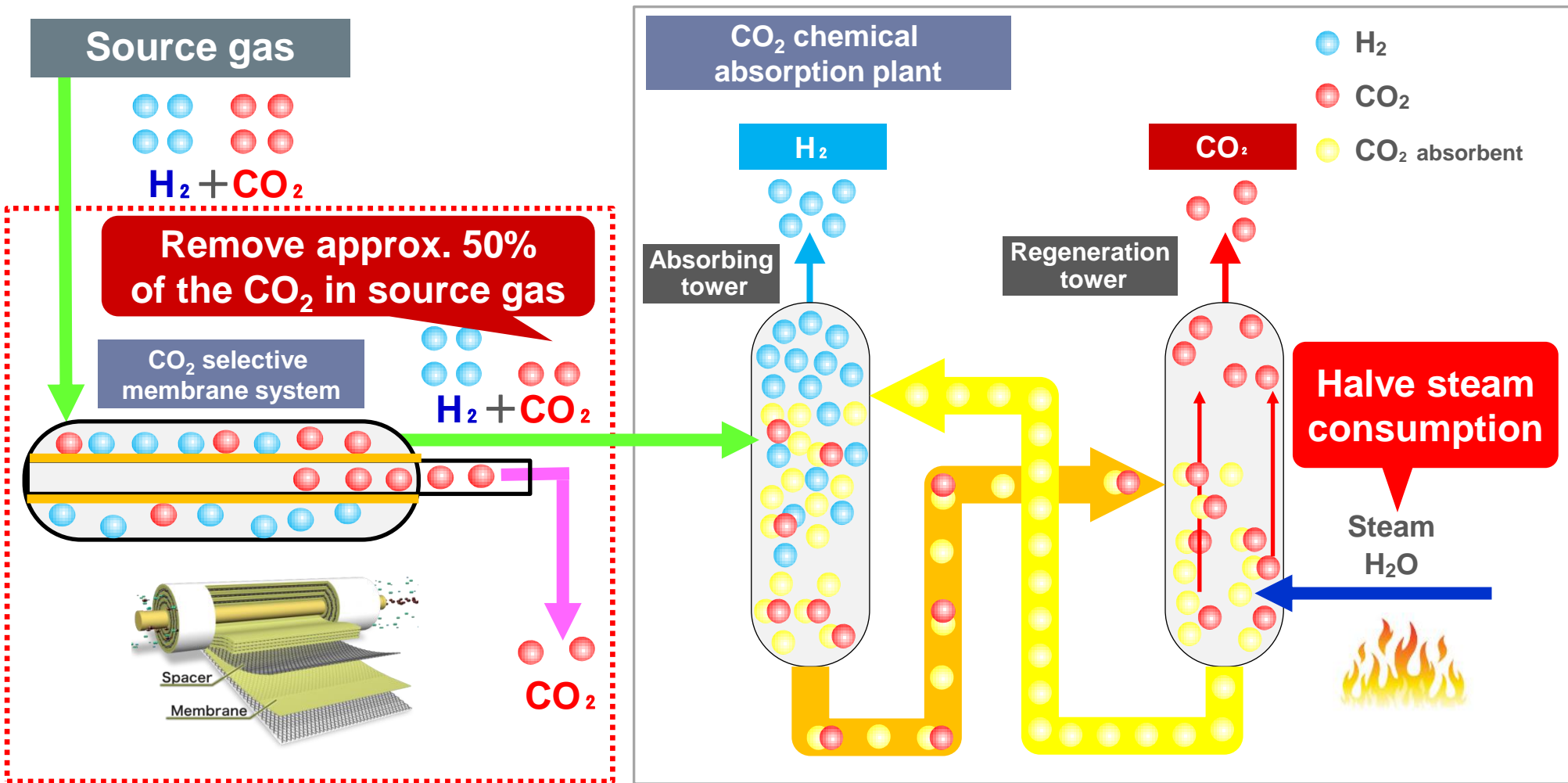

# Energy & Functional Materials Sector: CO<sub>2</sub> Separation Membrane

## CO<sub>2</sub> Separation Market (Forecast for 2030)

**Hydrogen production  
(refinery and chemical plants)  
Market: 520 million tons**



**Natural gas  
Market: 600 million tons**



**Market Size  
2.62 billion tons**



**Coal gasification combined  
power generation  
Market: 500 million tons**



**Coal to liquid  
Market: 200 million tons**

**Power generation and  
Steel manufacturing (CCS/EOR)  
Market: 500 and 300 million tons**



**Hydrogen stations  
Market: Unknown**

- Separation of H<sub>2</sub> and CO<sub>2</sub>
- Separation of CH<sub>4</sub> and CO<sub>2</sub>
- Separation of N<sub>2</sub> and CO<sub>2</sub>

# IT-related Chemicals Sector: Increase Film-type Touchscreen Panel Production

## Summary of Capacity Increase

- Product: Film-type touchscreen panel
  - Production capacity: 3 times the current capacity
  - Location: Dongwoo Fine-Chem
  - Start up: January 2018
- Dongwoo Fine-Chem  
touchscreen panel plant



## Sumitomo Chemical's Touchscreen Panel Production Capacity

### Film-type

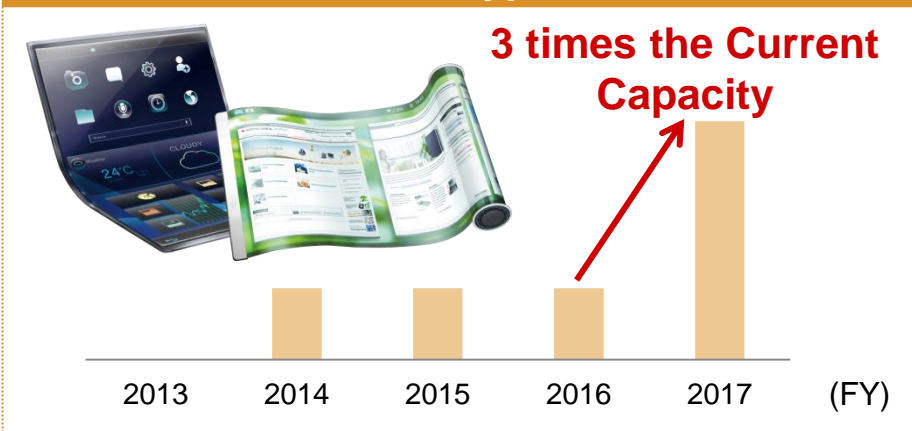

### Glass-type

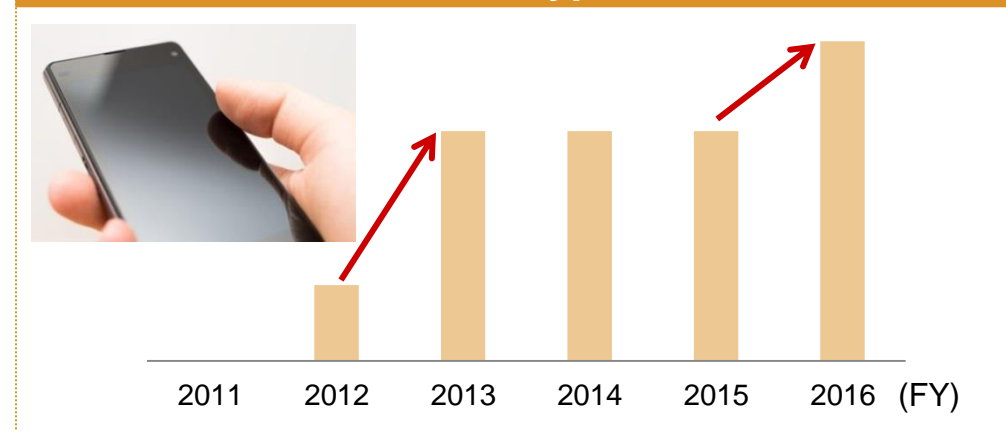

**Supporting flexible OLEDs in a variety of forms, from rigid types to foldable types and rollable types**

# IT-related Chemicals Sector: OLED-related Materials

## Roadmap for OLED-related materials development

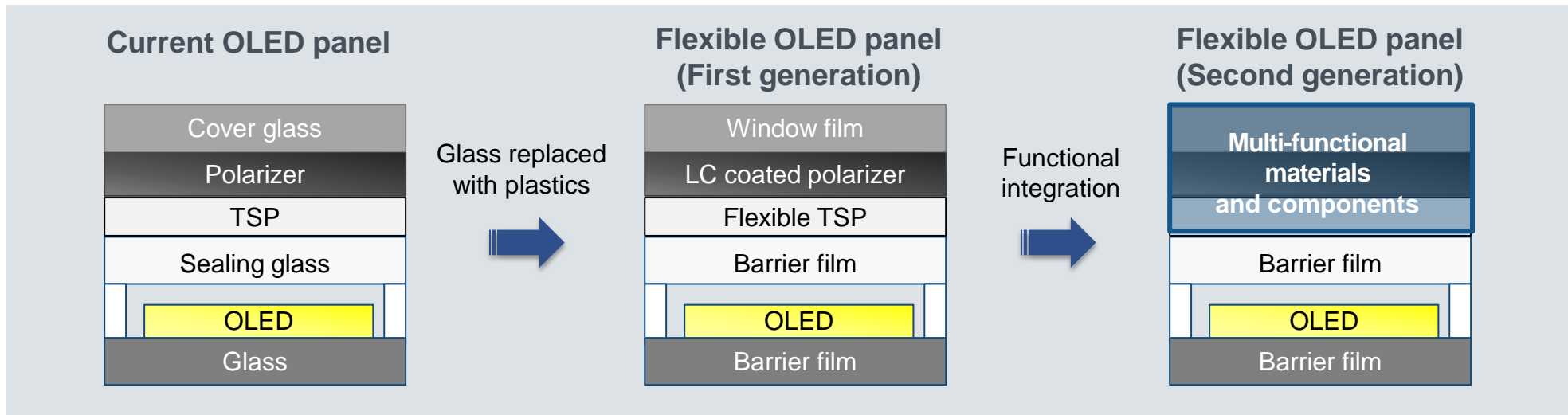

## Sumitomo Chemical's competitive advantages

**Material development capability**

as a diversified chemical company



**Product development capability  
Processing technology**

acquired through display materials business

**Contribute to the evolution and diffusion of OLED technology**

# IT-related Chemicals Sector: PLED Materials

## PLEDs' Advantages over LCDs

- Superior contrast, resolution, response speeds, and viewing angle
- Lower energy consumption
- Self-luminescent (no backlights required) and simpler display structure

## PLEDs' Advantages (Printing Methods) over Small Molecular LEDs (Evaporation Methods)

- Applicable to larger displays
- Greater potential to realize more cost-effective production

## Structure of Organic Light Emitting Diodes

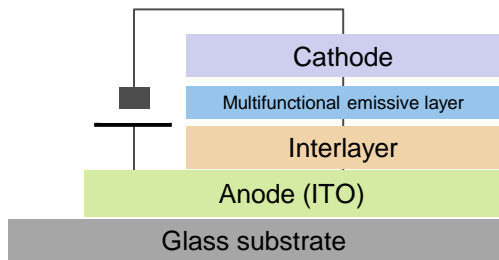

### Polymer light emitting diodes

Simple ← Structure of layers → Complicated

### Small-molecule organic light emitting diodes

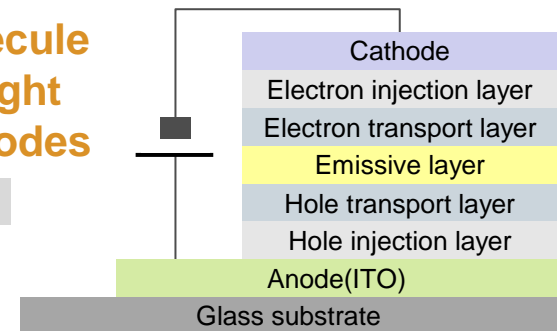

## Manufacturing Process

### Inkjet and other printing methods

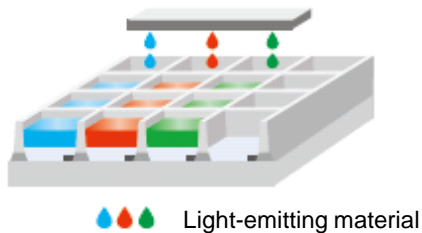

Unnecessary	←	Vacuum processing in organic layer deposition	→	Necessary
Unnecessary	←	Expensive mask	→	Necessary
High	←	Material use-efficiency	→	Low
Easy	←	Manufacture of large-sized display	→	Difficult

### Vacuum deposition method

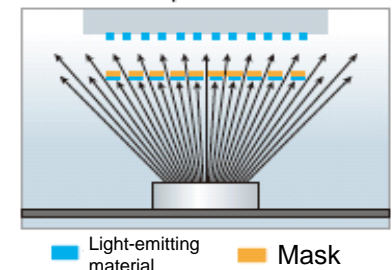



# IT-related Chemicals Sector: Strengthen Competitiveness of Polarizing Business

## Basic Strategy

- Capture demand from continually growing Chinese LCD manufacturers
- Thorough cost rationalization
- Global production balance optimization
- Expand sales for the growing OLED market

## TV LCD Panel Supply Capacity by Country

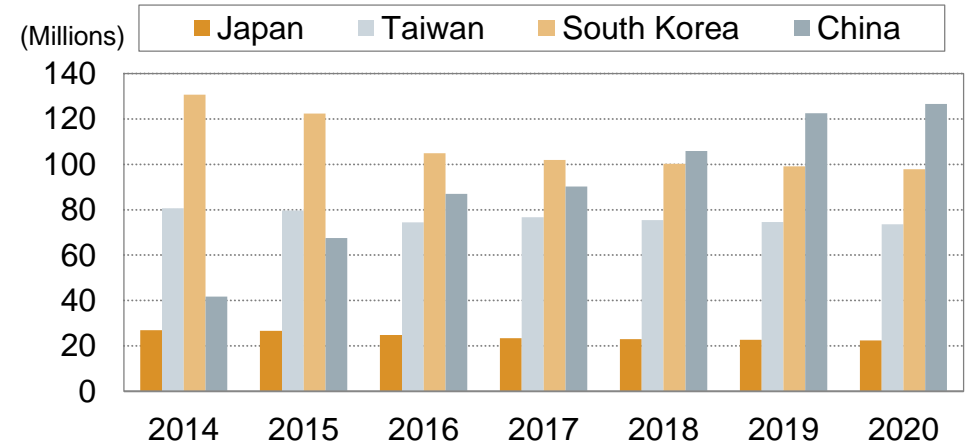

Source: IHS Markit Technology

## Specific Initiatives

	LCD	OLED
For TVs	<ul style="list-style-type: none"> <li>☑ Strengthen supply capabilities in China</li> <li>☑ Expand sales of polarizing film using our materials</li> <li>☑ Each line producing the kind of products it can most efficiently produce</li> </ul>	<ul style="list-style-type: none"> <li>☑ Launch coating-type retardation film</li> </ul>
For mobile devices	<ul style="list-style-type: none"> <li>☑ Focus on models where a certain level of profit can be expected</li> <li>☑ Expand sales of ultra-thin PVA stretched films</li> </ul>	<ul style="list-style-type: none"> <li>☑ Expand sales of circularly polarizing film</li> <li>☐ Launch liquid crystal coated-type polarizing film</li> </ul>

# Petrochemicals & Plastics Sector: Rabigh Project

## Progress on Rabigh Phase II Project



\* EC: Ethane cracker  
 FS: Feasibility study  
 PF: Project financing

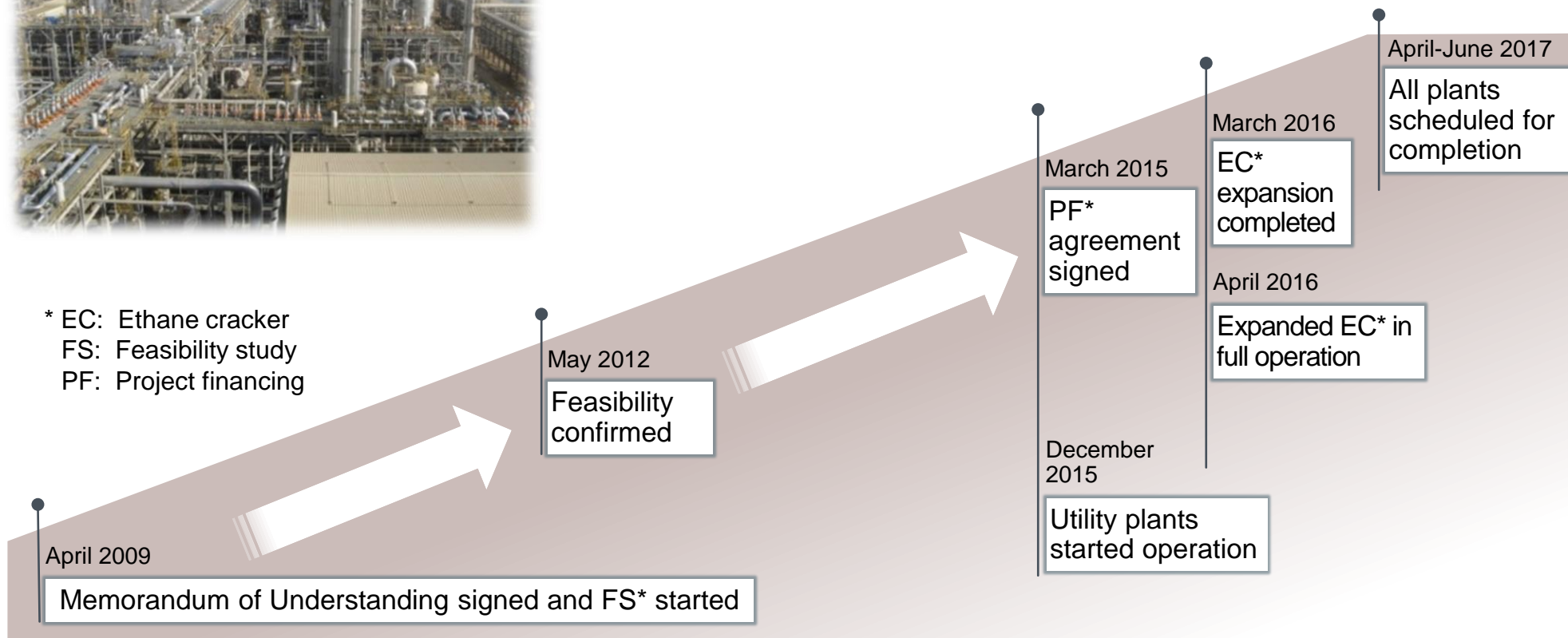

# ESG Initiatives: Strengthening Corporate Governance

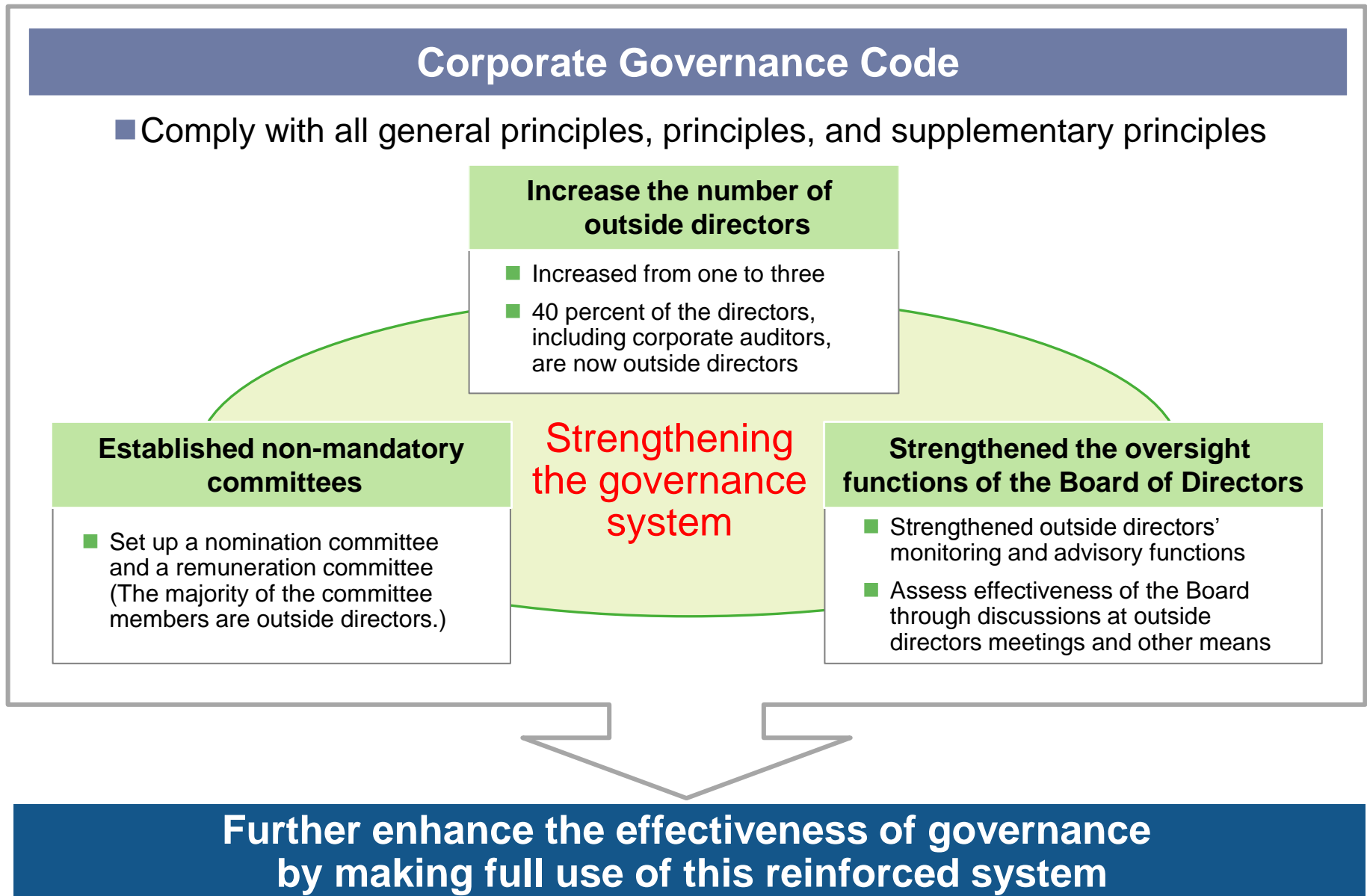

# ESG Initiatives: SDGs

## SDGs (Sustainable Development Goals)

The Sustainable Development Goals, adopted by the United Nations in 2015, consist of 17 goals and 169 targets, and represent a historical agreement involving all 193 UN member nations

## Sumitomo Chemical's initiatives towards achievement of the SDGs

Time	Initiatives
Sep. 2015	SDGs adopted at United Nations Sustainable Development Summit
Feb. 2016	SDGs discussed at SCC's CSR Promotion Committee
May.2016	SDGs webpage opened on SCC's website
June.2016	Launched <b>Sustainable Tree</b> program Workshop held at the Officers Liaison Meeting (4 times)
July.2016	Internal seminars (twice with 400 participants in total)
Aug. 2016	Presented SCC's policy on SDGs in its CSR report  Reported its SDGs initiatives at the Board of Directors Meeting

### Reference: 17 Sustainable Development Goals



An initiative for officers and employees to post on a dedicated website their ideas as to what they can do at work and in their private life to bring about a society with hope for future.

Period: 100 days from June to October 2016

Target: Officers and employees of all group companies

Number of posts: 6,005 in total

### Cautionary Statement

Statements made in this document with respect to Sumitomo Chemical's current plans, estimates, strategies and beliefs that are not historical facts are forward-looking statements about the future performance of Sumitomo Chemical. These statements are based on management's assumptions and beliefs in light of the information currently available to it, and involve risks and uncertainties.

The important factors that could cause actual results to differ materially from those discussed in the forward-looking statements include, but are not limited to, general economic conditions in Sumitomo Chemical's markets; demand for, and competitive pricing pressure on, Sumitomo Chemical's products in the marketplace; Sumitomo Chemical's ability to continue to win acceptance for its products in these highly competitive markets; and movements of currency exchange rates.